

Assessment of Ocean Thermal Energy Conversion

By

Shylesh Muralidharan

B. Tech. Mechanical Engineering, Pondicherry University, 1998
Master of Management Studies, University of Mumbai, 2001

Submitted to the System Design and Management Program
in Partial Fulfillment of the Requirements for the Degree of

Master of Science in Engineering and Management

at the

Massachusetts Institute of Technology
February 2012

ARCHIVES

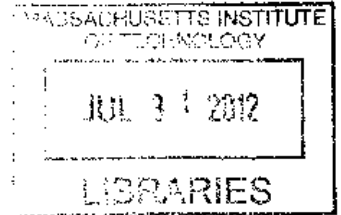

© 2012 Massachusetts Institute of Technology. All Rights Reserved

Signature of Author _____

Shylesh Muralidharan, January 30, 2012
System Design and Management Program

Certified by _____

E. Eric Adams, Senior Lecturer, Senior Research Engineer,
Dept. of Civil & Environmental Engineering
Thesis Supervisor

Certified by _____

Jessika E. Trancik, Assistant Professor,
Engineering Systems Division
Thesis Supervisor

Certified by _____

Ricardo Valerdi, Research Affiliate,
Center for Technology, Policy & Industrial Development
Associate Professor of Systems & Industrial Engineering, University of Arizona
Thesis Supervisor

Accepted by _____

Patrick Hale, Director,
System Design and Management Program

This page is left intentionally blank

Assessment of Ocean Thermal Energy Conversion

By

Shylesh Muralidharan

Submitted to the System Design and Management Program on January 31, 2012 in Partial Fulfillment of the Requirements for the Degree of Master of Science in Engineering and Management

Abstract

Ocean thermal energy conversion (OTEC) is a promising renewable energy technology to generate electricity and has other applications such as production of freshwater, seawater air-conditioning, marine culture and chilled-soil agriculture. Previous studies on the technology have focused on promoting it to generate electricity and produce energy-intensive products such as ammonia and hydrogen. Though the technology has been understood in the past couple of decades through academic studies and limited demonstration projects, the uncertainty around the financial viability of a large-scale plant and the lack of an operational demonstration project have delayed large investments in the technology.

This study brings together a broad overview of the technology, market locations, technical and economic assessment of the technology, environmental impact of the technology and a comparison of the levelized costs of energy of this technology with competing ones. It also provides an analysis and discussion on application of this technology in water scarce regions of the world, emphasized with a case study of the economic feasibility of this technology for the Bahamas.

It was found that current technology exists to build OTEC plants except for some components such as the cold water pipe which presents an engineering challenge when scaled for large-scale power output. The technology is capital intensive and unviable at small scale of power output but can become viable when approached as a sustainable integrated solution to co-generate electricity and freshwater, especially for island nations in the OTEC resource zones with supply constraints on both these commodities.

To succeed, this technology requires the support of appropriate government regulation and innovative financing models to mitigate risks associated with the huge upfront investment costs. If the viability of this technology can be improved by integrating the production of by-products, OTEC can be an important means of producing more electricity, freshwater and food for the planet's increasing population.

Thesis Supervisor: E. Eric Adams

Title: Senior Lecturer, Dept. of Civil & Environmental Engineering

Thesis Supervisor: Jessika E. Trancik

Title: Assistant Professor, Engineering Systems Division

Thesis Supervisor: Ricardo Valerdi

Title: Research Affiliate, Center for Technology, Policy & Industrial Development

Acknowledgements

I would like to thank a number of people who have contributed, both directly and indirectly, to my work at MIT and to the writing of this thesis. This thesis is possible because of the guidance, feedback and insights contributed by those around me.

I am sincerely grateful to Eric Adams, Jessika Trancik and Ricardo Valerdi who have provided support and guidance throughout this thesis and over the course of my education in MIT. They contributed with their professional knowledge, personal experiences and friendship. All their insights and suggestions added to my learning and vastly enriched my academic experience. I would also like to thank Lockheed Martin Corporation for providing me with the opportunity to work on this topic and the support throughout the duration of the project.

I am forever thankful to my wonderful colleagues in the SDM course who have patiently listened to all my ideas and provided valuable feedback. SDM is host to several great minds and my interaction with each one of them has been invaluable, helping me grow as a professional and a better individual. I would like to specially thank Pat Hale and the staff in SDM without whom many of things I accomplished in the past year would have been impossible.

On a personal note, I am grateful to my wife, Reshma, who was patient with me as I toiled away and provided encouragement when needed. And of course, last but not the least, I would like to thank my parents who are an eternal source of inspiration as they continue to provide strength and support through all my adventures.

TABLE OF CONTENTS

1. INTRODUCTION.....	9
1.1. Objective, Scope and Methodology.....	10
1.2. Methodology.....	11
1.3. Thesis organization	12
2. OCEAN THERMAL ENERGY CONVERSION.....	14
2.1. OTEC as an renewable energy technology	14
2.2. Water-energy nexus.....	14
2.3. History of OTEC	15
2.4. The thermodynamics.....	17
2.4.1. Closed-cycle	17
2.4.2. Open-cycle	19
2.4.3. Hybrid Cycle	21
2.5. Market locations for OTEC	22
2.6. Siting characteristics for OTEC plants	25
2.6.1. Shore-based	26
2.6.2. Moored/Floating Plantships	26
2.7. OTEC Demonstration Case Studies	27
2.7.1. Hawaii	27
2.7.2. Nauru	27
2.7.3. East coast of India.....	27
3. TECHNICAL ASSESSMENT OF OTEC COMPONENTS.....	29
3.1. Review of historical OTEC configurations	29
3.2. Technical readiness of OTEC components	36
3.2.1. Platforms.....	37
3.2.2. Platform mooring systems.....	38
3.2.3. Platform-pipe interface	39
3.2.4. Heat exchangers	39
3.2.5. Cold water pipe.....	40
3.2.6. Pumps and turbines.....	41
3.2.7. Power cables.....	42
3.3. Overall state-of-art of OTEC technology	42
4. ECONOMIC ASSESSMENT OF OTEC	44
4.1. Methodology.....	44
4.2. Cost Analysis	45
4.2.1. OTEC Plants 1 – 10 MW	47
4.2.2. OTEC plans 11 – 100 MW.....	47
4.2.3. OTEC plants >100 MW (up to 500 MW).....	48
4.2.4. OTEC Plant scale and costs	48
4.3. Cost drivers for various OTEC components	49
4.3.1. Uncertainty in cost components.....	53
4.4. Comparison of OTEC with other energy technologies.....	54
4.4.1. Levelized cost of energy.....	54
4.4.2. Comparison of capital cost and O&M costs.....	55
5. OTEC AND WATER SCARCITY.....	65
5.1. Introduction to seawater desalination	65
5.2. OTEC and Desalination	67
5.3. A study of water scarcity metrics	68

5.3.1.	Water Stress Indicator (WSI)	69
5.3.2.	Physical and economic water scarcity	70
5.3.3.	Water Poverty Index	71
5.3.4.	Water foot printing	73
5.4.	Freshwater from OTEC	74
5.5.	OTEC Case Study: BAHAMAS	76
5.5.1.	Climate and Geology	77
5.5.2.	Water Supply	78
5.5.3.	Regulation	79
5.5.4.	Water Tariffs	79
5.5.5.	Access to water	79
5.5.6.	Electricity in the Bahamas	80
5.5.7.	OTEC Potential in the Bahamas	81
6.	OTHER BY-PRODUCTS OF OTEC	87
6.1.	Sea Water Air Conditioning (SWAC)	87
6.2.	Chilled-soil agriculture	87
6.3.	Marine culture	88
6.4.	OTEC as an energy carrier	88
6.4.1.	Hydrogen	89
6.4.2.	Methanol	89
6.4.3.	Ammonia	89
6.4.4.	Jet Fuel	90
7.	ENVIRONMENTAL IMPACT OF OTEC	91
7.1.	Entrainment and impingement of organisms	91
7.2.	Upwelling of nutrient-rich deep ocean water	92
7.3.	Lowering surface temperature	92
7.4.	Other impacts	93
7.4.1.	Structure	93
7.4.2.	Construction and deployment noise and vibration	93
7.4.3.	Seabed disturbance	93
7.4.4.	Water circulation changes	94
7.4.5.	Electromagnetic field	94
7.4.6.	Light disturbances	94
7.4.7.	Chemical releases	95
7.5.	Ecological Risk Assessment – Comparison of OTEC with other ocean energy technologies	95
8.	CONCLUSION	97
8.1.	Attractiveness as a base load generator	98
8.2.	Importance of scale	98
8.3.	Key to the energy-water nexus	98
8.4.	Current Challenges	99
8.5.	Recommendation	100
8.6.	Discussion	101
8.7.	Future work	102
9.	SOURCES	103
APPENDIX.	110

LIST OF TABLES

Table 1: Developing countries with OTEC favorable temperature difference and depth	24
Table 2: Risks associated with the three different types of platform configurations	38
Table 3: Estimated capital cost /kW from previous OTEC literature	45
Table 4: Range of costs in OTEC plants (\$/kW installed)	52
Table 5: Levelized cost calculations of various sizes of OTEC plants	57
Table 6: Capacity Factor and levelized costs of various technologies	59
Table 7: Levelized capital costs and O&M costs of various plant types	61
Table 8: Range of LCOE for various energy technologies	64
Table 9: Average Capacities and costs for seawater desalination technologies	66
Table 10: The Bahamas: population and water demand statistics	82
Table 11: Capacities and costs of purchasing freshwater in The Bahamas	83
Table 12: Table to calculate the average price of water	84
Table 13: Break-up of cost from previous OTEC cost evaluations studies	111
Table 14: Comparison of risk ranking scores for three different ocean energy technologies.....	113

LIST OF FIGURES

Figure 1: Schematic of closed-cycle OTEC.....	18
Figure 2: Schematic of open-cycle OTEC.....	20
Figure 3: Schematic of hybrid cycle OTEC.....	21
Figure 4: Global ocean map showing OTEC resource zones with surface temp. color scale in °C	23
Figure 5: Lockheed design of moored OTEC plant (1978)	30
Figure 6: GE tower design for OTEC offshore plant	31
Figure 7: PREPA OTEC power plant layout (Proposed)	32
Figure 8: Design of SOLARAMCO Ammonia plantship (proposed)	33
Figure 9: Flowchart for VIWAPA OTEC pilot plant	34
Figure 10: Schematic of a 5 MW OTEC pre-commercial plant.....	35
Figure 11: Design of an OTEC plant with sub-sea condenser	36
Figure 12: Trend line of capital costs of OTEC plant for increasing plant sizes	48
Figure 13: Proportion of costs in historical OTEC designs (n=20)	51
Figure 14: Range of costs of OTEC components (includes estimated from various plant sizes)	52
Figure 15: Levelized capital costs vs. capacity factor for various energy technologies	60
Figure 16: Comparison of levelized capital costs and O&M costs of energy technologies	62
Figure 17: Average LCOE for energy technologies within a range of max. and min. values	64
Figure 18: Global map of WSI taking into account EWR.....	69
Figure 19: Global map of physical and economic water scarcity.....	70
Figure 20: Global map of water poverty index	71
Figure 21: Global map of water stress index	73
Figure 22: Map of the Bahamas.....	76
Figure 23: Comparison of risk ranking scores of ocean renewable energy technologies	96
Figure 24: Ocean map of OTEC resource zones around Americas with surface temp. color scale in °C..	110
Figure 25: Equation to calculate LCOE	110

1. INTRODUCTION

Energy from the oceans represents one of the largest renewable resources on the planet [1]. Of the several options to harness energy from the ocean – tidal energy, wave energy, osmotic energy and ocean thermal energy - ocean thermal energy has the most abundant of resources to the extent of at least 10,000 TWh/year [1]. This potential, in the context of world electricity consumption of 16,000 TWh/year, can satisfy most of the global demand for electricity. When coupled with its by-products such as freshwater and production of fuels, the technology may offer an attractive option for sustainable energy conversion.

Though the thermodynamics of the ocean thermal energy conversion (OTEC) process are inefficient and the economics of the technology does not match that of popular renewables such as wind or solar, availability of abundant and free ocean water makes this an attractive technology to study. In this study, we aim to understand whether it might be effectively designed to become cost-competitive with conventional energy technologies or at least with competing renewable energy technologies.

The open-cycle configuration of this technology uses water as a working fluid and produces desalinated water as a by-product. This makes it an attractive option for islands and other coastal locations which have challenges with the supply of both electricity and freshwater. The plantship configuration has the potential to be a mobile energy carrier, providing energy security for ocean-based defense applications. There are also applications such as seawater air-conditioning, marine aquaculture¹, chilled-soil² agriculture, for huge amounts of cold water that is pumped up to the surface from the deep ocean. These by-products and applications have the potential to balance some of the unfavorable economics of the technology and make this a viable solution for communities worldwide.

The technology attracted scientists and economists alike in the 1970s as the “next big thing” in renewable energy, due to the spike in oil prices, but fell out of favor a couple of decades later due to oil’s resurgence as the predominant fuel of the world. In the recent years, the renewed

¹ Aquaculture, also known as aqua farming, is the farming of aquatic organisms such as fish, crustaceans, molluscs and aquatic plants

² Chilled-soil agriculture is a method of growing produce that circulates cold water through the soil by a method of condensation, which creates a temperature differential between roots and leaves, simulating the seasons

push to adopt the technology is more a sustainable one. Currently there are several attempts across the world to reinvigorate this technology, which are at different stages of fruition. This report is a meta-analysis to look at ocean thermal technology with a systems perspective and offer directions to those who are looking at investing in this technology. It might require several continued and in-depth studies subsequent to this one, before this technology can be considered as a preferred source of base load in geographically favorable locations.

1.1.Objective, Scope and Methodology

OTEC's technical and economic viability as a reliable base load electricity supply has been validated by several engineering evaluations in the past including the experimental work performed at different government laboratories. Some of the initial apprehensions were around low cycle efficiency, disproportionate cost estimates compared to value derived from the technology, lack of potential as a comprehensive solution to national energy problems and of course the most significant factor of them all, capital-intensiveness. Recent studies and demonstrations by industry, government and academia have attempted to put things in perspective but the technology has always been affected by commercialization issues.

The lack of an operational prototype of the technology for most part of the last two decades has been due to the lack of commitment on the part of government or the private sector to invest and build a demonstration plant, except for some recent news on the industry taking concrete steps ahead³ such as the Lockheed Martin-Makai Ocean Engineering 10MW pilot plant in Hawaii and the recent Memorandum of Understanding between Ocean Thermal Energy Corporation and the Bahamian government to build commercial plants⁴. There have been projects in the past which have addressed specific challenges with OTEC implementation but there is yet no single project that comprehensively addresses the full range of issues for large-scale deployment of this technology.

The objective of this study was to perform a meta-analysis of existing literature in order to understand the state-of-art and alternative designs for OTEC technology. The project focused on assessing the technical readiness of all OTEC components and the economic feasibility of the

³ <http://www.economist.com/node/21542381> accessed 1st Feb 2012

⁴ <http://www.theonproject.org/2011/the-bahamas-sign-memorandum-of-understanding-to-build-two-otec-plants/> accessed on 1st Feb 2012

current OTEC technology, especially in comparison to other renewable technologies. The objective was also to study some of the bi-products of OTEC with a focus on one of them, freshwater, to study the market and economic feasibility of co-locating its production with electricity generation. There is also an assessment of environmental impact of building OTEC plants and its influence on the large-scale commercialization of the technology.

1.2.Methodology

Previous designs and assessment of the technology were reviewed to determine the state-of-art designs of OTEC and technical readiness of OTEC. The views of several OTEC experts, which were captured at the National Oceanic and Atmospheric Administration (NOAA) workshop of November 2009[2], were distilled to identify the critical parameters for major OTEC components. This was followed by an economic assessment of the technology through systematic review of cost valuations of twenty-four previous OTEC designs. The cost drivers for the major components were studied for patterns with respect to scaling the output of an OTEC plant.

The initial capital cost, the levelized capital costs, the levelized operation and maintenance costs, and the overall levelized cost of energy for different scales of OTEC plants were compared with other energy technologies to understand financial viability.

To study OTEC in the context of global energy demand and water scarcity, a systematic review of water scarcity indices was conducted. These were compared to the OTEC resource assessment maps to arrive at worldwide regions with high potential for co-locating electricity and freshwater production through open-cycle OTEC plants. This was further reinforced with the case study of the Bahamas - a group of islands which are both energy and water-constrained – as a potential market for co-locating generation of both products.

The final part of the research includes a study of other by-products of this technology followed by an assessment of the environmental impact of this technology on the marine and shore ecosystem and how its impact compares with those of other marine renewable energy technologies.

1.3. Thesis organization

The second chapter introduces the concept of ocean thermal energy conversion (OTEC), discusses the evolution of the technology through history, followed by thermodynamics of the technology and the various options of the Rankine cycle that are possible for OTEC plant configurations. There is also a discussion on the favorable worldwide markets for this technology and previously deployed demonstration plants.

The third chapter discusses the state-of-art for the major components of an OTEC system. It begins with the evolution of OTEC plant designs by looking at some of the popular configurations. It talks about the latest technical thinking on seven major cost components – platforms, platform mooring systems, platform-pipe interface, heat exchangers, cold water pipe, pumps and turbines, and power cables, and provides the cost drivers of the components based on the technical assessment and the scaling impact for each of the components.

The fourth chapter identifies the cost drivers for OTEC systems and analyzes the evolution of OTEC costs from previous OTEC literature. The main cost components of an OTEC system are then distilled and their impact on the overall cost of the system is studied. The uncertainties associated with each of the cost components are also discussed. There is also a comparison of the capital costs and the levelized costs of electricity for OTEC with other electricity generation technologies.

The fifth chapter discusses the relevance of OTEC in the context of water scarcity. It explores some models of water scarcity to identify the areas of water scarcity that overlap that with the OTEC-friendly locations worldwide. This is followed by a case study of the Bahamas (which is electricity and water-constrained) where OTEC is evaluated as a favorable technology to co-generate electricity and freshwater, making a case for a sustainable technology for island nations in the future.

The sixth chapter discusses some of the other by-products of OTEC such as sea water air-conditioning (SWAC), chilled-soil agriculture, marine aquaculture, mineral extraction and OTEC as an energy carrier, used in the production of hydrogen, methanol, ammonia and jet fuel.

The seventh chapter focuses on the environmental impact of OTEC followed by a discussion of a framework for assessment of the risks posed by this technology compared to other marine energy technologies.

Finally, in the eighth chapter we conclude and validate the hypothesis about the viability of OTEC, current challenges with commercialization, recommendations and conclusions of this study. It is followed by the key topics of future research and development that can be pursued to get a better understanding of this technology.

2. OCEAN THERMAL ENERGY CONVERSION

2.1. OTEC as an renewable energy technology

OTEC is a renewable solar source of energy as the ocean is a massive natural receptacle for solar energy. Annually the ocean absorbs energy from the sun, an amount equivalent to several thousand times the primary energy demand of the planet [3]. This energy is stored as heat in the upper surface layers of the oceans (35-100 meters) and redistributed between the ocean and atmosphere causing winds, waves, clouds, rain and warming up of the polar regions. At these depths, the temperature and salinity is uniform in the ocean. In most tropical coastal regions of the earth, the average temperature of these surface layers is between 27 and 29 °C. Beneath these shallow layers, the water temperature drops to about 4 – 5 °C as the depth increases to about 1000 m. Beyond this depth, the temperature drops only a few additional degrees even at an average ocean depth of 3650 meters [4]. The cold water that is below 1000 m is melted from the polar regions and stays in the ocean depths due to its higher density and mixes minimally with the warmer water layers above it. This creates a dual oceanic structure of warm water at the surface and cold water at depths beyond 1000 m, where possible. OTEC uses this temperature difference between surface ocean water and deep ocean water to operate a heat engine and produce electricity. To bring the cold water to the surface, OTEC plants require a large diameter intake pipe called the cold water pipe, which is submerged more than 1000 meters to access the cold water.

OTEC works best when the temperature difference between the surface of the ocean and the deep ocean water is at least 20 °C. The surface layers of the ocean act as a natural energy storage body permitting the OTEC plant to operate 24 hours per day. For continuous operation, it is important that this temperature difference is consistent and available throughout the year.

2.2. Water-energy nexus

As per a UNICEF report [5], one of mankind's most serious challenges in the 21st century will be a lack of adequate fresh water supply. Population growth, climate change and water pollution can lead to a drastic decline in the water supply worldwide. In 2010, about 80% of the world's population lived in areas with an impending threat to water supply [6]. Water

scarcity may become a main driver of OTEC plant adoption in several geographies of the world. The oceans cover 70% of the Earth's surface, making them the largest repository of unconverted energy and potential desalinated water[4]. OTEC plants can generate clean, renewable consistent electricity, desalinate water and also support a marine aquaculture economy which can power some of the island nations in the OTEC-friendly belt⁵. Though the initial costs to install these plants are significant, governments are evaluating support to these types of projects to infuse the grid with alternative and sustainable sources of power, solve freshwater and food issues and create additional jobs.

2.3. History of OTEC

The concept of OTEC originated in 1881 by D'Arsonval who proposed the initial concept based on the thermodynamic Rankine cycle using the closed-cycle concept with ammonia as the working fluid[7]. Georges Claude, a French engineer and former student of D'Arsonval, demonstrated the feasibility of this concept in 1928 in Ougree-Marhaye in Belgium using warm water at 30 °C from a steel plant for the evaporator and cold water at 10 °C from the Meuse River as the condensing fluid[8]. This test achieved turbine speeds of 5000 rpm and a power output of 50 kW. The success of this test helped Claude get financial support in 1930 for an OTEC demonstration project 1600m off the shore of Mantanzas bay in Cuba. This 50 kW project was operational for 11 days before the cold water pipe was destroyed in a storm [3]. In 1933, Claude installed an open-cycle plant off the coast of Brazil, for ice production on a 10,000-ton barge *Tunisie*. Designed with a turbine shaft power of 2000 kW of which 1200 kW were to be used for producing ice, the project was abandoned during deployment due to an unsuccessful attempt to attach the cold water pipe suspended from a semi-submersible float [9]. Despite these financial losses, Claude proposed a 40MW plant at Abidjan, Ivory Coast, in 1940 to the French government but the project proceeded slowly until 1948 when the government set up the company "*Energie de Mer*" with objectives to develop the concept. However this project too was abandoned in favor of a large hydro-electric plant in Abidjan. This was the end of active French interest in the technology [10].

⁵ OTEC-friendly belt is defined as the regions of the water with favorable temperature difference between surface and deep ocean water, elaborated further in this report.

Subsequently there was no commercial activity in OTEC until the late 1970s when Lockheed Corporation, the Dillingham Corporation and Hawaii State government completed an at-sea test of the OTEC system christened “Mini-OTEC” in August 1978 which successfully produced a net of 18 kW for 3 months before its planned shutdown [9].

The next major advancement came in 1980 – 1981 with the experimental OTEC-1 project at Kalua-Kona, Hawaii, by the US Department of Energy program aboard a modified T-2 tanker, *Chepachet* which served as a floating platform. This facility did not have a turbine-generator as it was not designed to generate electricity; rather, it was designed as a platform to test various OTEC-related technologies such as the platform, cold water pipe, the mooring systems, energy transfer systems and heat exchangers. Though it was terminated in May 1981 due to funding restrictions, OTEC-1 reached several milestones: successful deployment of a 670 meter long cold water pipe, mooring in 1,370 m of water, successful operation of the cold water pipe during wind, wave and current changes, operation of a shell-and-tube heat exchanger in a closed ammonia cycle at 38MW heat duty and demonstration of biofouling control with low-level chlorine injection.

In 1980, Saga University conducted OTEC experiments off the coast of Shimane and in 1981-82, a 100 kW gross power land-based plant was set up in the republic of Nauru[11]. Most of these were experimental programs initiated to support the OTEC design with data on advanced materials, design methods and processes. In 1986, following a drop in oil prices, there was a cut back in the funding of OTEC projects but small-scale studies and experiments have continued in various parts of the world until a land-based OTEC facility on the island of Hawaii successfully operated from 1993 to 1998, and produced a net 103 kW, still the world record for OTEC output[12].

The results from all these design studies, tests and pilot projects indicate that there is enough data available for commercially scaling up OTEC systems. Most tests have focused on ammonia as a working fluid in a closed Rankine cycle (except for Nauru, 1981 where Freon was used) due to its superior thermodynamic and thermal characteristics. Also, there is significant operational experience with commercial and industrial ammonia refrigeration, which is essentially an OTEC closed-cycle system in reverse operation.

Recent spatial studies [13][14] estimate maximum steady-state OTEC resources in the range of 3-5 TW which is more than the annual electricity demand of the planet. Hence OTEC still has a favorable case for feeding into the base-load demand in locations where the technology can make economic sense.

In recent developments, the US Department of Energy (DOE) awarded a \$ 1.2 million contract to demonstrate how the special cold water pipe can be designed and fabricated to carry large volumes of seawater for commercial-sized OTEC plants. This was followed by a two grants worth \$ 1 million awarded to Lockheed Martin in 2009. The first one was to develop a Geographic Information System (GIS)-based tool to estimate the energy that can be extracted from OTEC and identify sites favorable for OTEC and seawater air-conditioning. The second grant was to study life-cycle costs to demonstrate economic feasibility of utility-scale OTEC systems. Seawater air-conditioning has been successfully demonstrated in recent district cooling projects at Hawaii, Canada, Netherlands and Sweden by Honolulu Seawater Air Conditioning, LLC⁶.

2.4. The thermodynamics

2.4.1. Closed-cycle

There are two principal configurations usually proposed for OTEC. One is the closed-cycle as shown in [Figure 1]. In the closed-cycle configuration, there is a working fluid, usually ammonia, which is in a closed flow path. The working fluid is boiled using the heat from the warm ocean water using the hot water pipe in a heat exchanger called the evaporator. The working fluid vaporizes, passes through the turbine, turns a generator and produces electricity. Then the working fluid is condensed using a cold water pipe seawater system in another heat exchanger called the condenser. For the closed-cycle configuration, the working fluid should have specific thermodynamic properties so that maximum energy may be extracted per cycle over the temperature limits difference of around 20 °C. Usually a temperature difference of 20 °C or greater is required for a net positive generation of energy. Compared to a conventional power plant where the temperature difference is in the order of hundreds of degrees Celsius, this temperature difference is minimal and might even be considered infeasible in the conventional

⁶ <http://honoluluswac.com/casestudies.html> accessed on Feb 4, 2012

plants. This lower temperature difference leads to a lower Carnot efficiency⁷. Hence, if the OTEC power plant is supposed to produce useful amounts of power, it will require large amounts of both the heat source and the sink with large surface areas for both heat exchangers - the evaporator and the condenser.

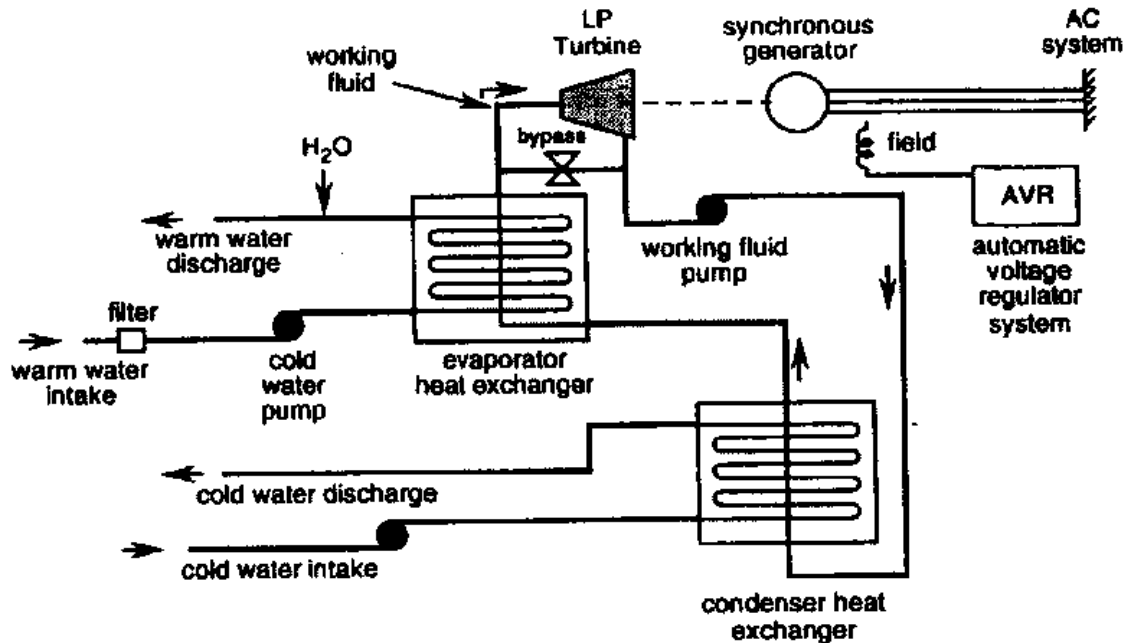

Source: [15]

Figure 1: Schematic of closed-cycle OTEC

The evaporator is one of the key elements in the design of the OTEC system since the loss of efficiency is determined mainly by this component. Several designs of evaporators with reasonable coupling of warm water and working fluid have been tried in the past. Deposition of living organisms on the inflow pipes and the degradation of surfaces by biological entities, called biofouling, which plagued some of the earlier designs, have also been addressed in the recent designs. Another solution to the problem of bio-fouling has been by using the hot water pipe intake at some point well below the actual sea surface: usually about 30 m but increasing the

⁷ Carnot cycle efficiency is the efficiency of an ideal reversible engine cycle called the Carnot cycle, a theoretical thermodynamic cycle proposed by Nicolas Léonard Sadi Carnot

depth of intake lowers the temperature at the warm water intake thus reducing the efficiency of the process and power output [15].

The condenser heat exchanger is another important component of the OTEC plant design as optimum condensation of the working fluid requires a specified volumetric flow rate of cold water. The auxiliary power required to pump the cold water has a direct impact and reduces the net electrical power output. Other significant auxiliary power consumption areas are warm water pumping, working fluid pumping, excitation system requirements and control system requirements [15].

Though several studies on OTEC have suggested different working fluids, ammonia was the original fluid proposed by D'Arsonval and was the fluid used in the "mini-OTEC" plant which operated successfully off the coast of Hawaii [16]. Subsequent studies have indicated that ammonia is the best theoretical fluid because of favorable thermodynamics.

2.4.2. Open-cycle

In the open-cycle OTEC as shown in [Figure 2], the working fluid is the warm seawater from the surface of the ocean. Warm seawater is brought to a low-pressure chamber to boil and the corresponding steam expansion drives a very low-pressure turbine. The condensation of the steam is accomplished using the cold seawater brought up by the cold water pipe from the deep ocean.

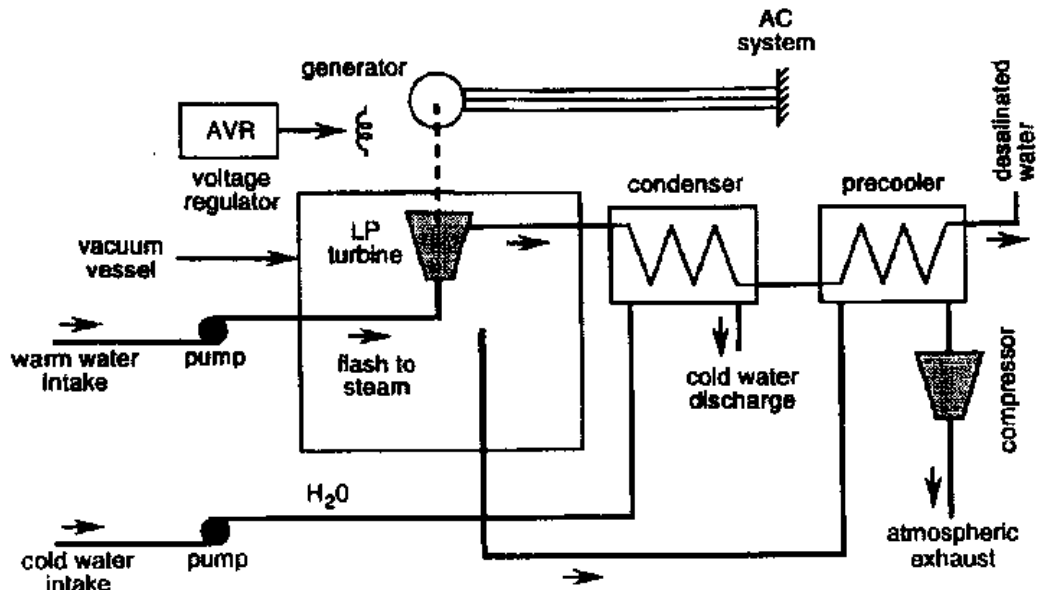

Source: [15]

Figure 2: Schematic of open-cycle OTEC

The low-pressure environment is attained in a specially designed vacuum vessel that is integrated with the low-pressure steam turbine. The steam exiting the vacuum vessel is salt free, and when condensed, the discharge is a desalinated one. The open-cycle process has an advantage over the closed-cycle process because it eliminates one of the heat-exchangers in the process and also has a by-product of economic value, fresh water. The challenge in this configuration is the platform size which is almost twice the size as that of the closed-cycle architecture for the same power output.

2.4.3. Hybrid Cycle

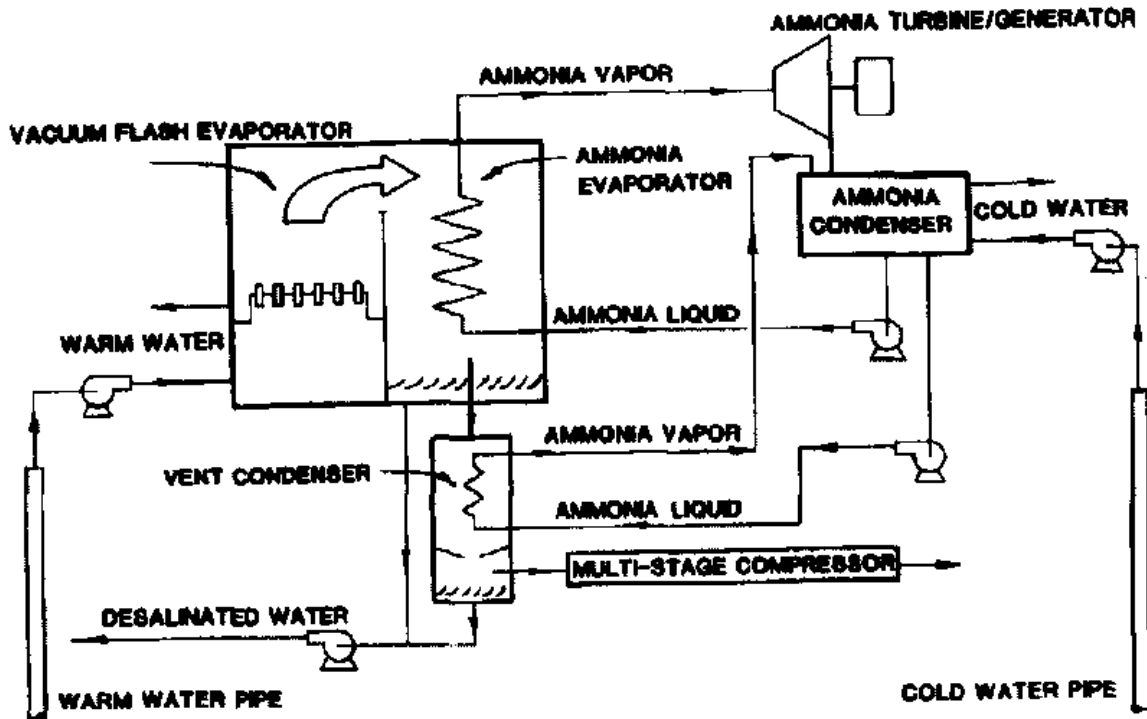

Source: [17]

Figure 3: Schematic of hybrid cycle OTEC

There is also a proposed third-concept of OTEC which is a hybrid of the open-cycle and closed-cycle design [17]. The main advantage of the hybrid cycle is that it can produce power in the closed-cycle and fresh water in the open-cycle. In this design both seawater and the closed-cycle working fluid are used in combination. The same vacuum vessel is used for flashing seawater into steam to produce desalinated water as well as the evaporation of the second working fluid through heat exchanged with the warm seawater. The second fluid is physically mixed with the warm seawater in an effervescent two-phase, two-substance mixture. The evaporated second working fluid is separated from the steam/water, and re-condensed as in the closed-cycle design. The phase change of the sea water/second working fluid combination results in useful work to drive a low-pressure turbine.

Other advantages of the hybrid-cycle over the pure open-cycle is that a commercially available ammonia turbine can be used to produce power compared to a large-diameter low-pressure

turbine and condensation can take place at a higher temperature increasing the fraction of recoverable thermal energy as well as reducing auxiliary power requirements to remove non-condensable gases.

2.5. Market locations for OTEC

Sixty percent of all seawater originates from the Polar Regions. The Atlantic and North Pacific oceans are fed by Arctic seas and all other major oceans are fed by Antarctic seas. Therefore, temperature of cold water at a given depth, approximately below 500 m, does not vary much throughout all OTEC regions. It is also a weak function of depth, with a typical gradient of 1°C per 150 m between 500 m and 1000 m and this gradient dropping even further, below the 1000 m depth. Previous studies have shown that if the appropriate sites are chosen with the natural resources and the socio-economic conditions favoring a market for OTEC by-products [3][18], the technology can be viable.

A US DOE study in 1981 identified ninety-eight nations and territories with access to the OTEC thermal resource (20 °C temperature difference between surface water and deep ocean water) within their 200 nautical miles EEZ⁸. For countries in the Caribbean and the Pacific, the thermal resource is available throughout the year round and OTEC-friendly⁹ deep ocean water is relatively close to the shore. These conditions make these the most attractive sites for cost-effective commercial OTEC plants. These sites can support land-based, shelf-mounted or moored platform designs.

Favorable OTEC thermal resource regions across the world are:

- Equatorial waters between 10°N and 10°S are the first choice but there are concerns raised for the west coast of South America due to temperature inconsistencies through the year, especially impacting the surface temperature during the winter months [19].
- Equatorial tropical waters stretching to 20°N and 20°S, again with exceptions of West Coasts of South America, Southern Africa, West Coast of Northern Africa, Horn of Africa and off the Arabian Peninsula due to similar weather temperature inconsistencies.

⁸ Exclusive Economic Zone

⁹ Depth of 1000 meters

- Countries along the east coast of Africa, Central and Latin American Islands and Islands in the Pacific Ocean.

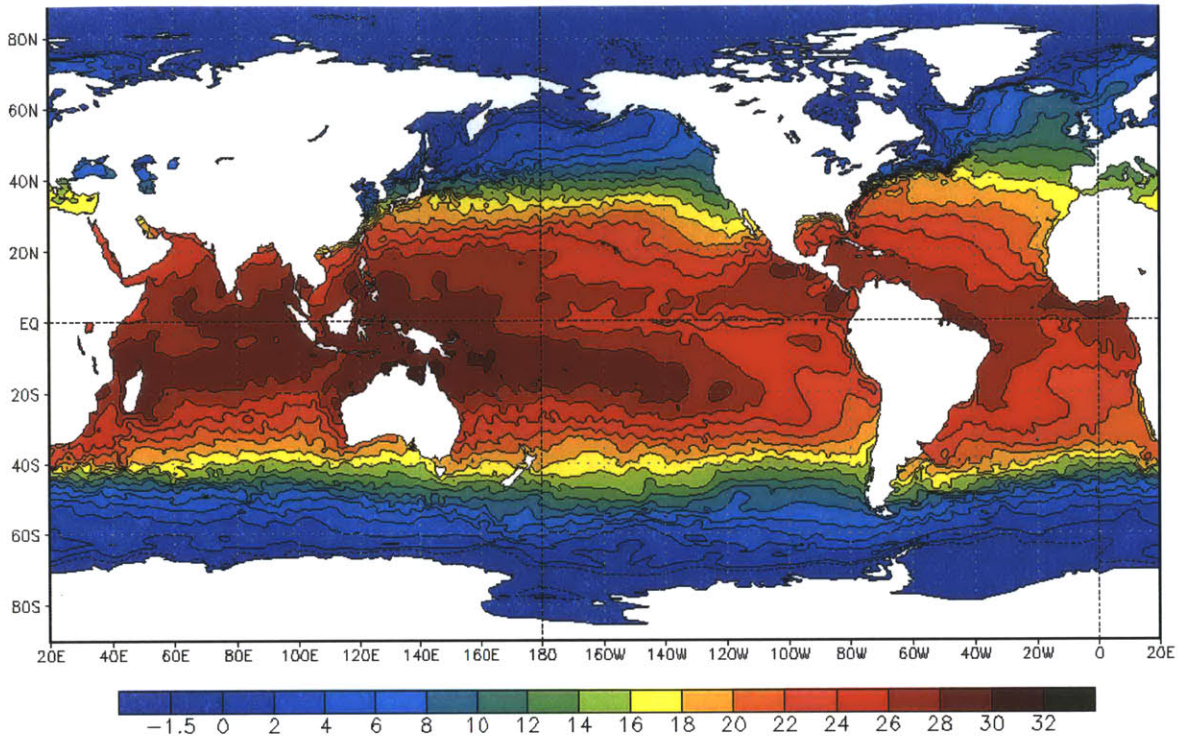

Source: http://polar.ncep.noaa.gov/sst/oper/global_sst_oper0.png accessed Feb 2, 2012

Figure 4: Global ocean map showing OTEC resource zones with surface temp. color scale in $^{\circ}\text{C}$

Some of the specific regions within the above OTEC resource zones, extracted from the high-temperature difference zones in Figure 4 are:

- Gulf of Mexico region covering the coastal regions of southeast Florida and the east coast of Mexico
- The coastal regions of the Caribbean Sea including the countries of Guatemala, Honduras, Nicaragua, Costa Rica, Panama, Cuba, Dominican Republic, Puerto Rico, Colombia and Venezuela
- In the North Atlantic Ocean, Guyana, Surinam, French Guiana and a small part of the Northern coast of Brazil
- North Western African countries of Guinea, Sierra Leone and Liberia

- In the Indian Ocean, the southern coastal regions along the Arabian Sea and the Bay of Bengal in India, Sri Lanka, Burma, Thailand, Malaysia, Singapore, east coast of Africa along the states of Somalia, Tanzania, Mozambique and the island of Madagascar.
- Northern coast of Western Australia, Northern Territory and some parts of Queensland and Papua New Guinea
- Several islands in regions of the South China Sea including Cambodia, Vietnam, Philippines and Indonesia

Some of the countries in this list are developing islands nations. These regions with the requisite OTEC temperature differential and the ocean shelf depth gradient for a near-shore OTEC plant are attractive markets for this sustainable energy source.

Table 1: Developing countries with OTEC favorable temperature difference and depth

Country/Area	Temp. Diff (°C) between 0 and 1000 m	Distance from Shore (km)	2010 Population (million)
Africa			
Benin	22-24	25	8.8
Gabon	20-22	15	1.5
Ghana	22-24	25	24.4
Kenya	20-21	25	40.5
Mozambique	18-21	25	23.4
São Tomé and Príncipe	22	1-10	0.2
Somalia	18-20	25	9.3
Tanzania	20-22	25	44.8
Latin America and Caribbean			
Bahamas, The	20-22	15	0.3
Barbados	22	1-10	0.3
Cuba	22-24	1	11.3
Dominica	22	1-10	0.1
Dominican Republic	21-24	1	9.9

Grenada	27	1-10	0.1
Haiti	21-24	1	10.0
Jamaica	22	1-10	2.7
Saint Lucia	22	1-10	0.2
Saint Vincent and the Grenadines	22	1-10	0.1
Trinidad and Tobago	22-24	10	1.3
U.S. Virgin Islands	21-24	1	0.1
Indian and Pacific Ocean			
Comoros	20-25	1-10	0.7
Cook Islands	21-22	1-10	0.0
Fiji	22-23	1-10	0.9
Guam	24	1	0.2
Kiribati	23-24	1-10	0.1
Maldives	22	1-10	0.3
Mauritius	20-21	1-10	1.3
New Caledonia	20-21	1-10	0.3
Philippines	22-24	1	93.3
Samoa	22-23	1-10	0.2
Seychelles	21-22	1	0.1
Solomon Islands	23-24	1-10	0.5
Vanuatu	22-23	1-10	0.2

Source: http://www.nrel.gov/otec/design_location.html

2.6.Siting characteristics for OTEC plants

To site shore-based plants or moored/floating plantships, there are specific characteristics for a location to qualify as a potential OTEC site:

2.6.1. Shore-based

- Consistent source of warm surface seawater close to the shore, relatively clean of pollutants – this is to avoid additional effort required to clean the warm water taken in by the OTEC system
- Typical tropical weather with a mean annual surface water temperature of at least 25°C
- Steep offshore slope quickly reaching depth of 1000 meters within a few kilometers of the coast. Since water temperatures at these depths are the same worldwide (about 5°C), the temperature difference will be about 20°C, the minimum considered necessary for OTEC
- A shore site suitable for construction activities including excavation.
- Elevation of an OTEC plant as close to sea level as possible to minimize pumping-power requirements.
- Offshore topography that is suitable for deploying the cold-water pipe. The topography should be conducive to the pipe design, which has evolved from corrugated-steel pipe sections, flanged and bolted together (as used by Claude in his early design) to a Fiber-reinforced-plastic design anchored to the bottom by weights.

2.6.2. Moored/Floating Plantships

Similarly, there is set of suitable siting characteristics for locating OTEC plantships¹⁰ which may be moored or floating in a specified geographical area [20]:

- Water temperature differences between surface and the deep ocean water exceeding 20°C
- Surface temperature of 25°C or greater
- Surface currents less than 1 kph¹¹
- Deep currents less than 0.4 kph
- Winds of 13-30 kph
- Wave height \leq 4 meters

¹⁰ Vessels designed to use temperature differences in ocean water while floating unmoored or moving through such water, to produce electricity or another form of energy capable of being used directly to perform work, and includes any equipment installed on such vessel to use such electricity or other form of energy

¹¹ Kilometers per hour

2.7. OTEC Demonstration Case Studies

There have been several demonstrations of OTEC in the past several decades. All these studies have helped further the cause of the technology by helping scientists and engineers understand some part of the OTEC system better. A few of the most popular demonstration studies are:

2.7.1. Hawaii

One of the first-ever OTEC plant was commissioned in 1979 in Hawaii. It was an offshore demonstration 50 kW closed-cycle plant which used up 40 kW in running the plant and produced 10 kW as the net output. The platform was moored by using a 30,000 lb weight. Cold water at a temperature of 4.4°C was drawn from a depth of 670 m. Ammonia was used as the working fluid and the cold water pipe was made out of Polyethylene to reduce bio-fouling which was one of the biggest concerns for the cold water pipe then. The heat exchangers were made out of Titanium. At 120 hours, it was one of longest continuous running time of an OTEC plant [3].

2.7.2. Nauru

The Hawaii demonstration plant was followed by a 100 kW land-based plant in the Republic of Nauru in October 1981 built by Japan. The system operated with a temperature difference of about 20°C between the surface water and the cold ocean water at a depth of 500–700 m. A depth of 580 m was covered by pipeline length of 945 m. The heat exchanger tubes were surface-treated with titanium to improve performance. Freon-22 was used as the working fluid. Freon-22 was considered less harmful to the environment compared to ammonia. Again the material used for the cold water pipe was polyethylene. This project tested the load response characteristics, turbine, and heat exchanger performance tests. The results were fairly satisfactory with the efficiency of the turbine recorded at over 80%. The plant achieved a continuous power generation of 31.5 kW and an operational record of 10 days.

2.7.3. East coast of India

National Institute of Ocean Technology (NIOT), India, built a 1 MW floating plant off the coast of Tamil Nadu close to Tuticorin in the South east coast of India. The plant was integrated on a floating barge and had a gross power generation capacity of 1 MW and net power of 500 kW. The plant was supposed to have ammonia as a working fluid with evaporators coated with

special steel on the ammonia side to enhance nucleate boiling. Power was generated through a four-stage turbine. The floating barge was to be moored on a single point mooring at a depth of 1200 meters by using a one-meter-diameter high-density cold water pipe made of polyethylene. The project was abandoned because of problems that crept in while deploying the pipe to the platform. Following this incident, the project shifted focus to desalination using the OTEC cold water pipe.

3. TECHNICAL ASSESSMENT OF OTEC COMPONENTS

3.1. Review of historical OTEC configurations

One of the earliest configurations for an OTEC project was the design of an OTEC plantship to produce ammonia via hydrogen[20]. A baseline 100 MW OTEC plantship design was developed with an output of 313 tons of ammonia per day. This design was then extrapolated to a 500 MW ammonia and liquid hydrogen plantship which could produce ammonia at very competitive costs compared to the then prevailing market prices of ammonia by the sixth subsequent ship that could have been built for this purpose. The major cost drivers of this design were the platform, heat exchangers and the ammonia plant which would use the electricity produced on-board to convert electrolytic hydrogen into ammonia.

This was followed by a pure electricity-production design [21] based on a 240 MW spar-type configuration which was designed specifically for survivability and station-keeping as the initially proposed locations for OTEC plants were along the Gulf of Mexico and off the Florida coast, which were hurricane belts. In this configuration, most of the structure was under the surface of water, shielded from hurricane winds and waves. The configuration consisted of four major systems; the platform, the cold water pipe, the mooring, the anchor and the power modules [Figure 5]. The power module consisted of the two large heat exchangers, turbo-generators, pumps and the power conditioning equipment with the entire module detachable for periodic maintenance. Of the two types of heat exchangers that were proposed for this configuration, costs of the aluminum-tube heat exchangers were cheaper than the titanium-based one by \$ 100 million.

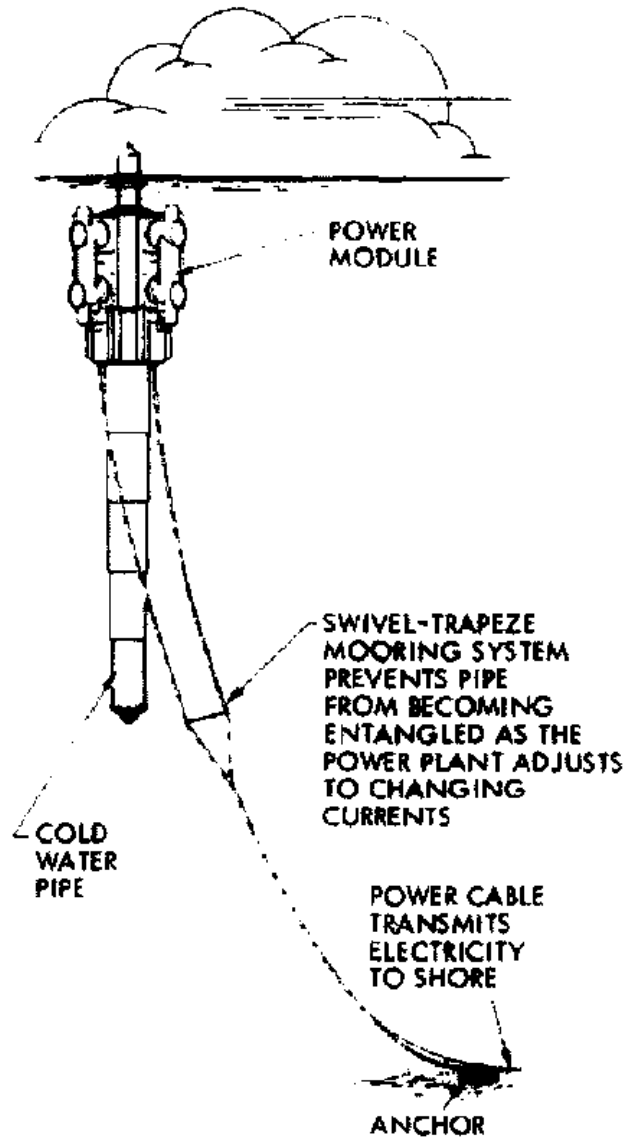

Source: [21]

Figure 5: Lockheed design of moored OTEC plant (1978)

Some of the other conceptual designs proposed historically include two tower-mounted designs – One design was the General Electric (GE) tower-mounted OTEC facility [Figure 6] which was planned to be at Kahe Point, Oahu, Hawaii with a cold water pipe made of steel along the sloping sea bottom with modular components for power production, pumps, and heat exchangers with a plan for convenient transfer of components to and from their mounting positions on the tower via elevators, semi-automated subsea transfer equipment and derricks. The second was a similar 40

MW tower-mounted plant [Figure 7] sited close to the shore on the continental shelf off Punta Tuna, Puerto Rico proposed by Puerto Rico Electric Power Authority (PREPA).

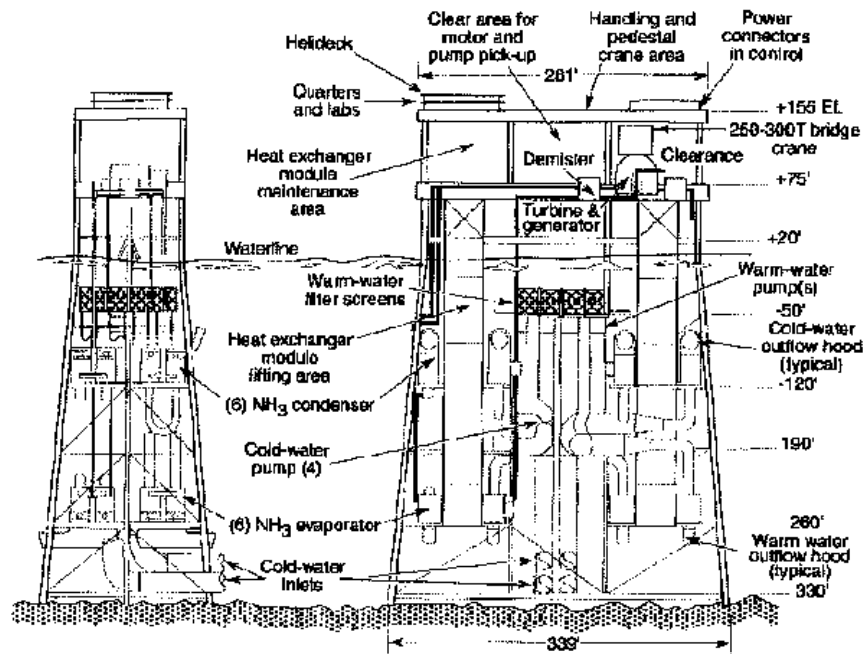

Source: [3]

Figure 6: GE tower design for OTEC offshore plant

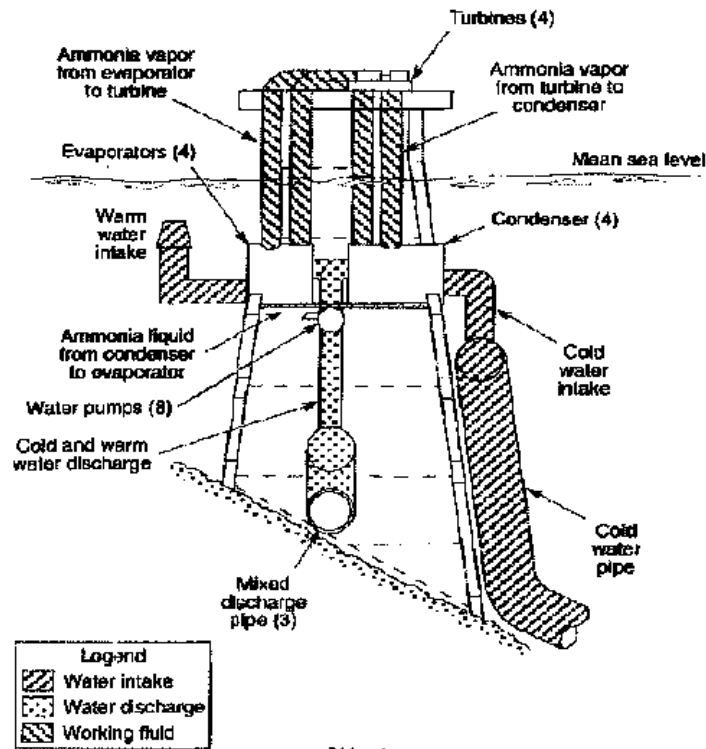

Source: [3]

Figure 7: PREPA OTEC power plant layout (Proposed)

Other designs such as the 40MW OTEC grazing plantship was proposed by the solar Ammonia Company (SOLARAMCO) to be situated south of Hawaii for ammonia production. This design used a concrete-based barge-type hull with rotatable thrusters provided below the hull for sea-keeping and grazing [Figure 8].

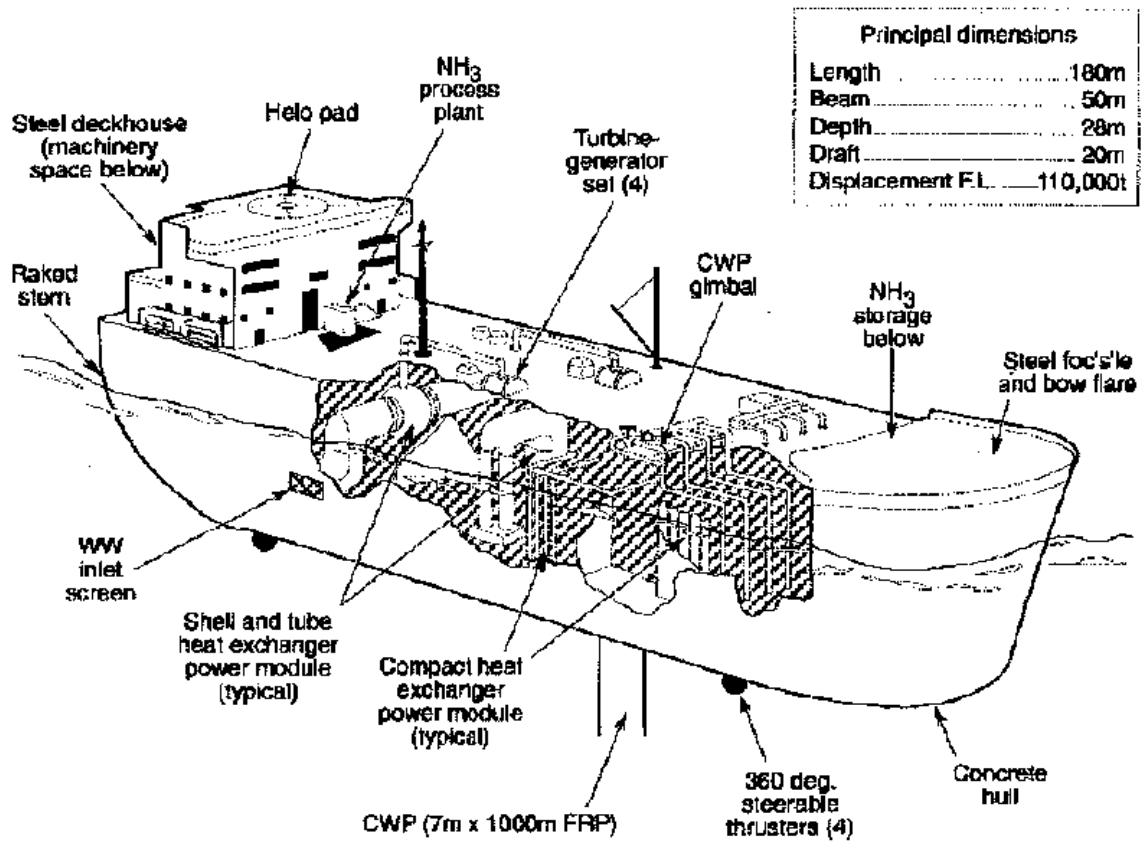

Source: [3]

Figure 8: Design of SOLARAMCO Ammonia plantship (proposed)

One of the earliest designs of a combined electricity and water production OTEC design was proposed by Virgin Islands Water Power Authority (VIWAPA) as a 12.5 MW shelf-mounted tower delivering 10MW of electricity and 190,000 m³ of fresh water with a portion of the discharged cold water used for marine culture experiments [Figure 9].

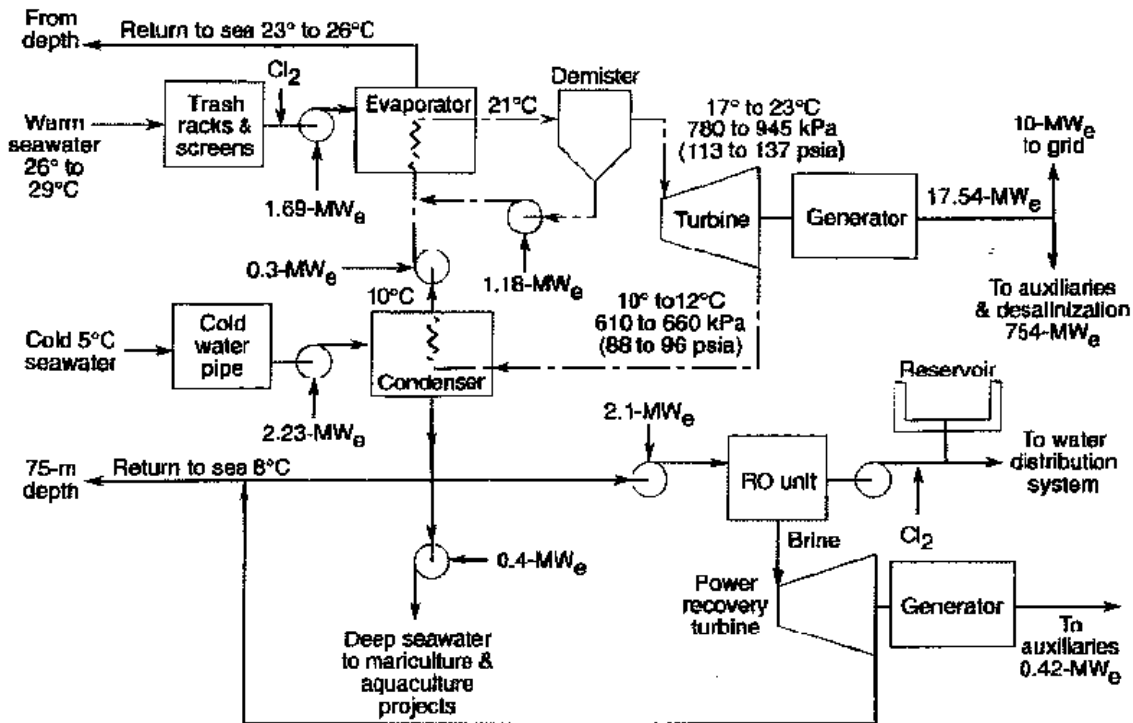

Source: [3]

Figure 9: Flowchart for VIWAPA OTEC pilot plant

There have also been detailed evaluation of economic feasibility and financial viability of OTEC by Vega [12], [19], [22] that showed that in Hawaii, plants would have to be floating platforms sized at about 50-100 MW and any size smaller than that might not be cost-effective. The plant design was based on a closed-cycle for electricity production and on a second stage, using the effluent water streams from the power cycle, for desalinated water production. This facility included ammonia as the working fluid. The design of a pre-commercial floating hybrid OTEC plant [Figure 10] had an open-cycle process housed in a barge or ship with the electricity transmitted to shore via a submarine power cable and the desalinated water via a small hose pipe

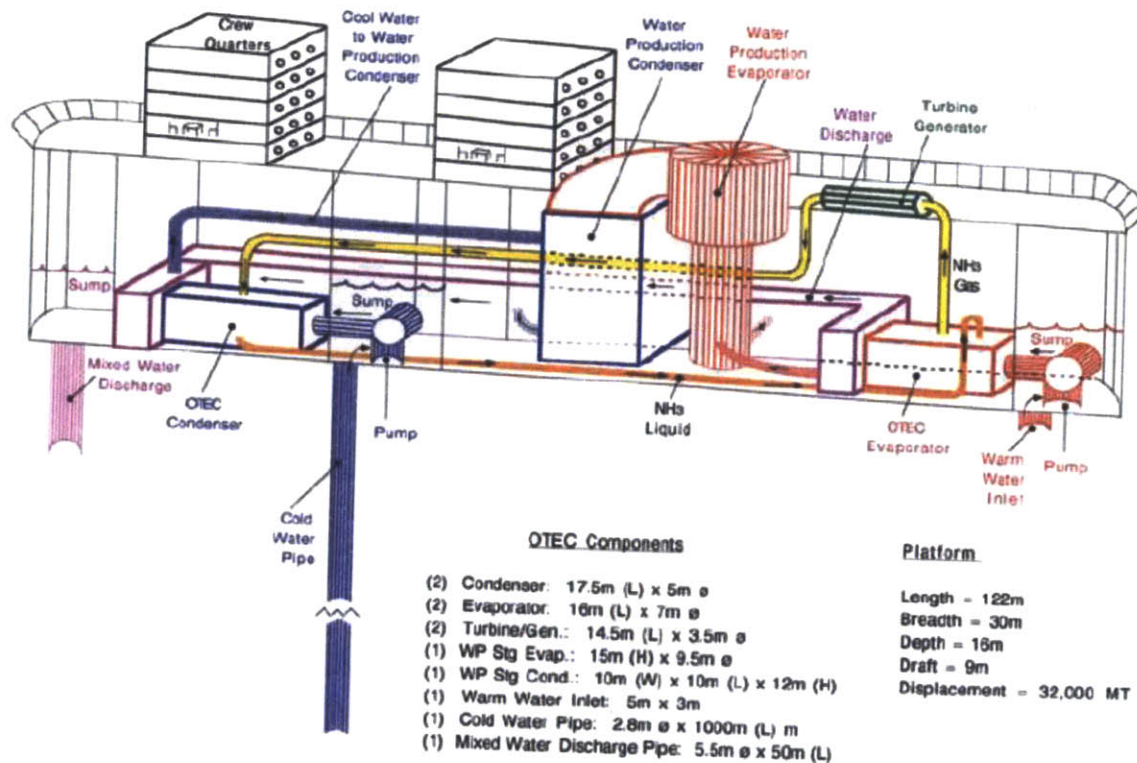

Source: [12]

Figure 10: Schematic of a 5 MW OTEC pre-commercial plant

Recently, there has been new architecture explored [23] in the form of a 100 MW floating vessel OTEC plant designed with the purpose of reducing capital costs. The main difference in this technology was the shifting of the condenser from near the surface to the deep ocean, alleviating OTEC's main challenge of pumping cold ocean water to the floating vessels through cold water pipes. This architecture was proposed to reduce the costs and technical problems related to large OTEC systems. When the condenser is placed in a colder environment, the efficiency of the condenser is improved too. And the coldwater pipe is now not directly exposed to the harsh ocean environment. However, the supporting vessel for the condenser has to be specially designed for this application. There are several cost-saving elements associated with this new configuration to the extent of upto 45% compared to conventional OTEC capital costs in the form of reduced platform costs, evaporator costs and installation costs.

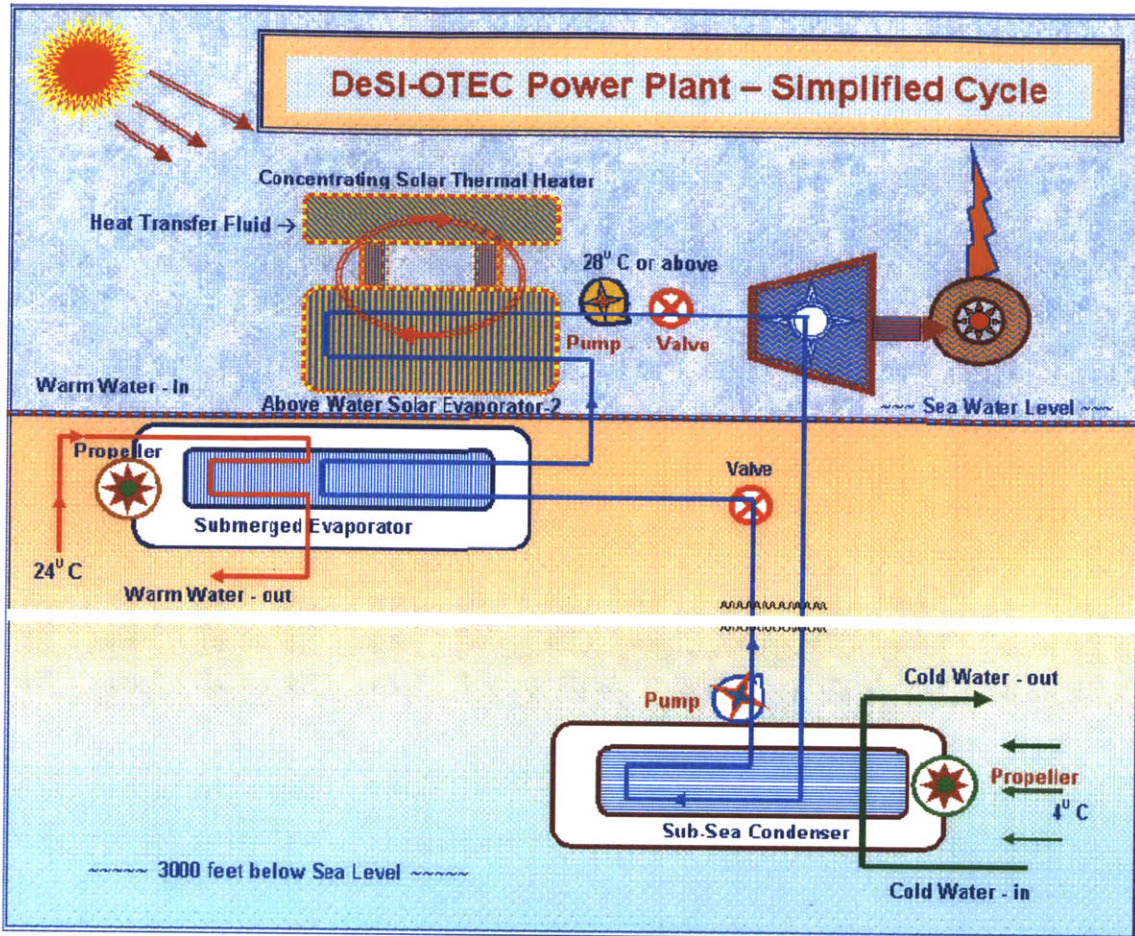

Source: [24]

Figure 11: Design of an OTEC plant with sub-sea condenser

3.2. Technical readiness of OTEC components

NOAA's Office of Ocean and Coastal Resource Management (OCRM), in cooperation with the Coastal Response Research Center (CRRRC) collaborated on a workshop in November 2009 to compile qualitative information[2] utilizing the knowledge of several experts in the field to focus on the *state-of-art* of OTEC components and technical readiness of the technology to be scaled to a size greater than 100 MW. This effort identified seven critical components of any OTEC system as the limiting ones for advancement of this technology. They are:

- 1) Platform
- 2) Platform Mooring Systems
- 3) Platform/pipe Interface

- 4) Heat Exchangers (HX)
- 5) Power Cable
- 6) Pumps and turbines
- 7) Cold water pipe

3.2.1. Platforms

Since the 1980's, developments in meteorological and oceanographic data gathering methods, primarily driven by the petroleum industry, has led to more reliable and weather-resistant platform designs. Three platform designs have been identified as being most feasible for OTEC projects: semi-submersible, spar, and (mono-hull) plant ship. All these three designs have been tested and operational in other industries such as offshore oil, wind farms, etc. There are no significant challenges for their use in an OTEC application.

The life cycle of a platform in an OTEC facility has well-established procedures. Monohull manufacturing uses a Floating, Production, Storage, and Off-loading Unit (FPSO) for construction while semi-submersible platforms have standard offshore rig fabrication procedures. Spar platforms present the most difficulties for installation and operation because they require deepwater work, which increases the risk and complexity of the project. However, the spar configuration is most favorable for the cold water pipe attachment because there is less variable motion at the joint [25]. Also, the platform should be either built on-site or transported from an offsite location, depending on the OTEC system requirements. Operation and maintenance procedures for these platforms are well-established and include maintenance of machinery and removal of biological growth on the submerged sections. Decommissioning of platforms is regularly performed in other industries and should not cause significant challenges for OTEC facilities. Though OTEC can heavily borrow platform technology from other mature industries, there should be unique standards for all the OTEC equipment/technology. The standards can lay the ground for interoperability for various components and support innovation specific to this industry.

Table 2: Risks associated with the three different types of platform configurations

Platform Type	Motion/survivability risk	Arrangement difficulty	Cost	Technical Readiness
Semi-submersible	Small	Medium	Medium	High
Spar	Small	High	Medium-High	Medium
Ship shape/monohull	Medium	Low	Low	High

Source: [2]

3.2.2. Platform mooring systems

This technical readiness of this component also been influenced by advancements of similar components in other industries. Deep water platform mooring technologies have made the most advancement in the past three decades increasing the depth limit from a few hundred meters in 1980s to several thousand meters in the past decade [26]. Mooring platforms can also borrow technology from the offshore oil industry which uses similar platforms in a more demanding environment. Technologies such as GPS and high-resolution Sound Navigation and Ranging (SONAR) along with software which aid precision-modeling of platform moorings have enabled enhanced mooring systems.

Design, fabrication, and construction of the platform mooring components are established as standardized procedures with customization procedures varying with increasing platform size, weight, bottom slope and exotic seafloor characteristics. Mobilization, deployment and decommissioning of platform mooring, though labor-intensive and expensive, have also been identified as processes that can be borrowed from the offshore oil industry with minimum customization. Installation, operation and maintenance of the platform mooring components are relatively simple and reliable with existing technology. Maintenance focuses on periodic replacement/repair of integrity monitoring instrumentation and mitigating the impact of marine fouling on equipment. Bio-fouling is seen as a major risk and deviation for deep-sea OTEC projects compared to near-shore oil platforms [17]. Bio-fouling will have a major impact on the lifespan of the equipment, the load carrying capacity of the equipment and resulting maintenance schedules. For initial prototype plants, the current mooring technologies are adequate in terms of

materials, design and fabrication but challenges can be anticipated as the plant's output goes beyond 100 MW.

3.2.3. Platform-pipe interface

Since the 1980s, significant advances in material science along with sensor and modeling technology have helped the OTEC industry to design lighter, stronger and durable platform-pipe interfaces. The experience of the industry until now has been with pipes ~1 m diameter and this can challenge the feasibility of 10 meter diameter pipes for 100 MW. The offshore oil industry's expertise in multiple risers up to 1 meter diameter can be scaled for large OTEC applications. The currently accepted platform pipe interface designs are:

- Flex pipe attached to a surface buoy,
- Fixed interface
- Interface with a gimbal

Fixed and gimbal interfaces are considered simpler to design and manufacture compared to flex interfaces. The fixed interface has a simpler maintenance process and can be scaled easily to larger facilities, compared to flex and gimbal interfaces. The flex and gimbal interfaces are prone to frequent maintenance and cleaning due to additional fatigue points and connections. Horizontal interfaces are difficult to deploy compared to vertical interfaces and the ability to detach the cold water pipe also adds complexity and costs to the interface. There is still no clear technical anticipation of the special requirements of custom platform-pipe interfaces for large OTEC facilities. In the past, the platform-pipe interface has been a vulnerable component for failure, either due to loss of the cold water pipe or leakage issues at the interface. Local climate, currents and wave patterns, the ability to couple/decouple the cold water pipe will impact the overall complexity of design of the system.

3.2.4. Heat exchangers

Advances in heat exchangers since the 1980s have been primarily driven by industries such as aerospace, power plant, petroleum, cryogenic, Liquefied Natural Gas (LNG), geothermal, etc. Today heat exchangers have improved heat transfer co-efficient due to the use of new materials such as cost-effective titanium, aluminum alloys and plastics. Fabrication processes and surface

enhancements have also added to improved capacity of heat exchangers. Heat exchangers have been developed for several closed-cycle applications. For OTEC, the most suited heat exchanger shapes are shell and tube (constructed from titanium, carbon steel, stainless steel, copper-nickel, or aluminum), plate-and-frame and aluminum plate-fin with the most appropriate working fluids being propylene and ammonia for these designs.

Manufacturing of shell-and-tube heat exchangers is labor-intensive and transporting them to the OTEC location and integrating them with the facility will be the key to their performance. Operation and maintenance of heat exchangers are fairly simple incorporating human visual inspection and monitoring. Decommissioning of heat exchangers is also simple and both metals and working fluid can be recycled. Shell-and-tube heat exchangers are the most scalable for large OTEC plants using the modular design of smaller heat exchangers (upto 5 MW) which have been manufactured and tested till date.

Stainless steel and titanium plate-and-frame heat exchangers are easier and cheaper to manufacture, though it is still a challenge to scale them to large capacities. Plate-and-frame heat exchangers have challenges of being submerged because their caskets are not fully welded and have to be dry during operation. Aluminum plate-fin heat exchangers are similar to the shell and tube design, fabricated mostly with brazened aluminum, though with lesser power output per module, having the ability to be scaled in modules.

3.2.5. Cold water pipe

There has been a significant improvement in the materials and fabrication process of cold water pipes in past couple of decades. In the 1980s the materials used were E-glass/vinyl ester, steel and/or concrete and typically had a synthetic foam core sandwich design whereas current materials include R-glass/vinyl ester, fiber-glass and carbon fiber composite. Currently, the fabrication of the cold water pipe will likely include VARTM¹² and large protrusion processes. VARTM allows sandwich core manufacturing and/or stepwise manufacturing which helps mitigate pressure issues in the pipe in deep water. As with other components, design and deployment of cold water pipe for less than 10 MW OTEC facility is well-understood. Pipes of ~2 m are being successfully demonstrated but pipe designs of larger diameters for larger OTEC

¹² Vacuum Assisted Resin Transfer Molding

plants are yet to be developed. The cold water pipe can be designed to last the life of the OTEC plant (30 years) with fiber optic technology incorporated for monitoring performance of the pipe. Coating and additives achieve smooth interior surfaces of the pipe which can mitigate biofouling of the pipe. Emergency preparedness of the pipe increases the complexity of the pipe as well as the platform-pipe interface. Future designs might include ability to detach the pipe in the event of extreme weather to mitigate loss to the system. Decommissioning and recycling the pipe is straightforward with established procedures borrowed from the offshore oil industry.

3.2.6. Pumps and turbines

Since the 1980s when OTEC technology was first proposed, pumps and turbines have not undergone major technological revamps except in enhanced lightweight, lower friction materials and electronic monitoring of health of the pumps and turbines. Commercially available turbines for OTEC plants are currently made of steel, carbon steel and chromium. While large-scale axial flow turbines are commercially available in the 5-10 MW range, manufactured by the leading turbine manufacturers, further scale can be achieved by a modular design of these turbines. Scaling up power production through modular design of turbines improves the net power production and reliability of the plant. Usually, there is a redundancy incorporated in the number of turbines installed to account for maintenance without compromising the operations of the OTEC system. Operations and maintenance procedures for these turbines are simple and involve routine inspection and periodic repair of components. Monitoring for internal damage as well as for damage due to foreign objects is done using electronic sensors. The turbines are designed to last for the life of OTEC plants (30 years) and 85-90% of the turbine materials can be recycled.

The design of cold and warm water pumps is usually the axial flow impeller design mounted on the platform. These pumps are highly efficient in the range of 87-92% and are commercially available from numerous vendors. The main materials used in pumps are carbon steel, stainless steel, copper and insulating material. Like turbines, pumps are an important component of improving the reliability of the system and are usually designed for redundancy. Due to the critical nature of pumps in the design of OTEC systems, spare pumps and spare working fluid should be readily accessible at the facility. Pump operations can also get complicated with submerged designs. Large-scale OTEC facilities can be designed with multiple-pump solutions

with commercially available off-the-shelf specifications which can be easily integrated into the OTEC system.

3.2.7. Power cables

Offshore wind farms in recent years have highly enhanced the understanding of high voltage undersea cables since the 1980s. Connections of upto 50 kV are common connecting platforms to the grid. In the last ten years, there have been 10 sea-crossing AC cables upto 500 kV and 20 DC cables up to 500 kV. Cables under 20 miles long are likely to be AC and use single/ three phase > 69 kV. Cables longer than 20 miles are likely to be DC in order to reduce transmission losses. The cables also have a steel armoring to protect it throughout the 30-year lifespan of the OTEC plant. There are well-established codes and standards for cable construction available from Institute of Electrical and Electronics Engineers (IEEE), International Electro-technical Commission (IEC), and American Petroleum Institute (API).

For cables less than 500 kV, design and fabrication is commercially available so larger OTEC plants might require custom design of cable. Cable design is dependent on the design of the mooring system and cable interface on the platform side is currently identified as the most technically challenging part of designing the cable system. Operations and maintenance is standardized with periodic marine growth removal, full cable inspection and annual maintenance of substations using divers and Remotely Operated underwater Vehicles (ROV).

3.3.Overall state-of-art of OTEC technology

The state-of-art of technology for each of the OTEC components is ready to develop and deploy a small-scale (less than 10 MW) floating, closed-cycle OTEC plant using current design, manufacturing, materials and deployment methods. But the technical ability to scale to an output larger than 100 MW is still being researched. Existing platform, platform mooring, pumps and turbines, and heat exchanger technologies can be scaled using modular design but some other components such as marine power cable to transfer energy, the cold water pipe and the platform/pipe interface present fabrication and deployment challenges for ≥ 100 MW facilities. The ability to anticipate and understand the technical challenges associated with large-scale OTEC plants and integrated OTEC plants producing electricity and other by-products, will play an important role in the commercialization of the technology and determine the future

development of this energy technology. There is a need to thoroughly understand the technical readiness and scalability to a larger (> 100 MW) commercial facility incorporating some of the system-level benefits of an OTEC facility such as desalination, Sea water air-conditioning, Mineral extraction, Aquaculture, Hydrogen production, Methanol production, etc. Hence it might be important to prototype and deploy an operational plant of 10 MW before the commercialization and development of OTEC of a larger commercial (≥ 100 MW) facility is undertaken.

4. ECONOMIC ASSESSMENT OF OTEC

The economic variables affecting the design and deployment of an OTEC plant range from macro-factors such as economic environment of the plant location and market for OTEC-generated electricity and by-products to micro-factors such as the scale of the plant, the cost components including capital costs, operations and maintenance cost, capacity factor, etc. Though OTEC does not have major fuel cost implication (it uses abundant ocean water), the relationship between the scale of the plant and the corresponding capital costs have made OTEC plants very unattractive compared to fossil fuel plants, and even compared to some of the renewable technologies such as solar and wind.

But an important feature of OTEC technology that improves its financial viability is the option to co-locate production of various by-products with electricity generation. Depending on the configuration of the plants (open-cycle, closed-cycle or hybrid), this technology can produce fresh water, cold water for aquaculture and energy-intensive products such as hydrogen and ammonia and metals such as aluminum and uranium. In this study previous literature of cost evaluations of OTEC plants is analyzed based on several different configurations and to arrive at an assessment model for cost drivers of the components of OTEC projects.

4.1. Methodology

The methodology adopted in this part of the study includes a meta-analysis of several historical cost evaluation studies of OTEC. These are cost projections rather than cost data.

- Twenty eight models of cost evaluation of OTEC projects were analyzed, taken from the OTEC literature spanning 1975 to 2011. These cost evaluations were studies of OTEC plants of varying sizes and configurations.
- All available data were normalized to 2010 \$ figures, using the GDP deflator, for consistent data analysis
- The data were then analyzed and the behavior of different cost components across plant sizes and configurations were studied
- Major cost components were identified from these studies and the range of variation in these costs across the different plant sizes and configuration types was quantified.

- The range of costs for the major components of the OTEC system was analyzed to understand the impact of each of the components on the overall costs of the system
- Finally, the levelized cost of energy through OTEC is compared with other existing technologies to understand the viability of OTEC vs. the other technologies

4.2. Cost Analysis

In the United States, the most comprehensive OTEC developmental cost evaluations were done as part of DOE-funded design programs in the 1980s. There have also been cost studies of varying detail by other investigators worldwide. The estimating procedure varies across these studies and is different due to variations in architecture of the plant, deployment methodologies, location, financing options and other technical details, but some common cost components are compared and analyzed. Initially all studies which reported a total capital cost for OTEC were taken into account in the present study. Then the details of each of the cost evaluation studies were documented and converted to 2010 \$ using the GDP deflator index.

Table 3: Estimated capital cost /kW from previous OTEC literature

Year	Plant description	Plant Size (MW) net	Plant type-cycle	Output	\$ (2010)/kW installed
1990	Land-based [19]	1	OC ¹³	Electricity / Water	28,000
1990	Land-based with second stage water-production [19]	1	OC	Electricity / Water	35,400
1990	Land-based [19]	10	OC	Electricity / Water	16,400
1990	Land-based with second stage water production [19]	10	OC	Electricity / Water	22,600
1980	Moored plant [3]	40	CC ¹⁴	Electricity	11,400
1982	Phase IV PREPA [3]	40	CC	Electricity	13,000
1982	GE tower-mounted [3]	40	CC	Electricity	16,000
1985	Land-based [3]	40	CC	Electricity	17,000
1980	Grazing plantship[3]	46	CC	Ammonia	8,410
1990	Floating (Moored) [19]	50	H ¹⁵	Electricity / Water	10,600

¹³ Open-cycle

¹⁴ Closed-cycle

¹⁵ Hybrid

1990	Land-based [19]	50	CC	Electricity	12,600
2010	Open-cycle [27]	51	OC	Electricity / Water	10,751
2010	OTEC plantship - closed-cycle[27]	54	CC	Electricity	8,430
2009	OTEC unit (sub-sea floating vessel design) [23]	100	CC	Electricity	2,680
2010	Floating ship [24]	100	CC	Electricity	4,000
2009	OTEC conventional floating unit [23]	100	CC	Electricity	4,250
2011	Grid-connected [28]	100	CC	Electricity	13891
1990	Methanol plantship [19]	200	CC	Methanol	7,580
2011	LMC ¹⁶ Grid-connected [28]	200	CC	Electricity	11098
1978	LMC spar-type configuration (AL-tube) [21]	240	CC	Electricity	4,020
1978	LMC spar-type configuration (TI-tube) [21]	240	CC	Electricity	5,110
1990	Ammonia plantship [19]	386	CC	Ammonia	3,990
2011	LMC Grid-connected [28]	400	CC	Electricity	8684
2011	LMC Energy carrier [28]	400	CC	Ammonia	8944
1975	OTEC Ammonia plant ship – APL [20]	500	CC	Ammonia	2,430
1975	OTEC Ammonia plant ship [20]	500	CC	Ammonia	3,250
1975	OTEC Ammonia plant ship – TRW [20]	500	CC	Ammonia	5,090
1975	OTEC Ammonia plant ship - LMC [20]	500	CC	Ammonia	8,660

The feasibility of OTEC depends on whether investors in this technology can foresee a positive return on investment with a relatively low uncertainty in the cost components. Comparing the 28 different models of OTEC plants cost evaluations in the literature, OTEC projects can be classified into three categories based on scale of the power output of the plant.

- OTEC plants 1 – 10 MW
- OTEC plants 11 – 100 MW

¹⁶ Lockheed Martin Corporation

- OTEC plants >100 MW (up to 500 MW)

4.2.1. OTEC Plants 1 – 10 MW

This category of OTEC plants is land-based or shelf-mounted. These are plants specially designed for island applications and primarily produce electricity but can also be used for fresh-water production, aquaculture, sea water air-conditioning systems and fuel production. Open-cycle configuration is preferred for these small-scale plants. The installation costs of these plants are very high, in the range of 16,400 - 35,400 \$/kW. This is because all OTEC have a large amount of overhead costs, as part of setting up the plant. But even though the installed cost is quite high compared to other technologies, it can be partially offset by the economics of OTEC by-products discussed later in this report. At this scale, it becomes imperative that electricity production be coupled with one or more of the by-products for the project to make economic sense. It is estimated that plants of this size range can supply 0.45 million to 9.2 million gallons (1700 to 35,000 m³) of fresh water per day which will be adequate to cater to a population of 4,500 - 100,000 residents [29]. This scale of plants is suggested as the appropriate size for some of the small island developing states (SIDS) listed earlier in this report, especially the ones where the depth of 1000m drops quickly within 10 kilometers of the shore.

4.2.2. OTEC plants 11 – 100 MW

This category of OTEC plants can be land-based or shelf-mounted plants [3] and in some cases, a floating plantship configuration. At the scale of 10-100 MW it becomes imperative to minimize the size of the plant and save costs. Hence the closed-cycle configuration, which allows for a more compact design compared to the open-cycle configuration, is preferred at this scale. The floating plantships can be placed within a few kilometers of the shore and can be connected to the power grid on the shore through undersea submarine cables. Though mostly designed to produce electricity, there is a grazing ship configuration where the electric power produced on-board is used to generate gaseous hydrogen and nitrogen to form ammonia, which stores energy and can be shipped to the shore. The output of ammonia from a 40MW grazing ship is about 125 tons/day [20]. The capital costs for configurations in this category drop from 16,000 \$/kW installed for a 40 MW tower-mounted configuration to 4000 \$/kW installed, for a 100 MW floating ship. Recently a sub-sea condenser architecture has been studied [23] which can bring down the installed capital cost of a 100 MW OTEC plant to 2650 \$/kW

4.2.3. OTEC plants >100 MW (up to 500 MW)

This category of OTEC plants consists mainly of floating ships generating power using the closed-cycle configuration. The capital costs of OTEC configurations in this category can be as low as 2,430 \$/kW installed for a 500 MW ammonia plantship. [Table 3] shows that large scale OTEC plants are usually used for production of energy-intensive products or energy carriers such as hydrogen, ammonia or methanol. At this scale, it becomes important to analyze the economics of extracting more value through by-products from an OTEC plant in addition to generation of electricity.

4.2.4. OTEC Plant scale and costs

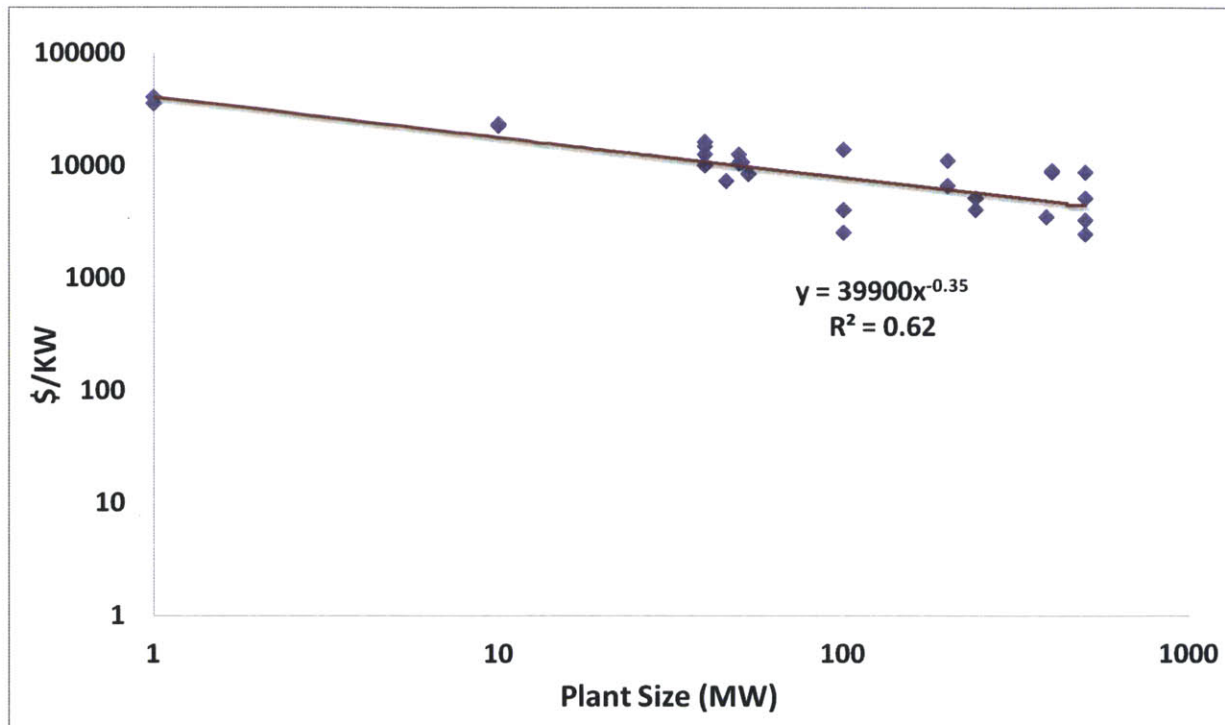

Figure 12: Trend line of capital costs of OTEC plant for increasing plant sizes

When the installed capital costs/kW are plotted against the plant size on a log-log plot [Figure 12] the trend shows a reduction in the capital cost of an OTEC plant with an increase in the plant size (MW). If the costs from [Table 3] are analyzed, the power regression line follows the equation

$$y = ax^{-b}$$

Where y = capital cost of the plant (in \$/kW) and x is the plant size (in MW), the intercept a = 39902 and the exponent b = 0.35 and therefore the cost reduction with plant size in this analysis is followed by the trend line

$$y = 39900x^{-0.35}$$

This trend line indicates that as plant size doubles, the costs/kW of installed costs decreases by 22% (approx.). A one-fifth reduction in capital costs / kW for every doubling of plant output is a significant reduction, and if the projection holds true, can make the technology attractive at large-scale outputs.

4.3. Cost drivers for various OTEC components

While several of the components in an OTEC project can be borrowed from industries such as offshore oil drilling, a major cost driver for OTEC plants that is not yet accurately accounted for is the modification cost for adapting the conventional design from these industries for OTEC environments. The costs in twenty-eight cost evaluation models used in this study has been grouped into six major cost categories: the platforms, power generation systems, heat exchangers, energy transfer systems, water ducting systems and deployment and installation processes.

The major cost driver for platforms (or land-based containment system, in case of a land-based plant) is the customization costs associated with modifying the conventional design from other industries to execute OTEC plants. This might also impact the operation and maintenance costs of the platform and allied platform services. The decision to build the platform onsite or transport it from an offsite location will also be a significant cost driver of this component. The fabrication of the platform fabrication becomes challenging with the increase in the scale of output of the plant. A larger facility will house a significantly increased amount of equipment multiplying the cost and difficulty of fabrication and deployment. The platform is the framework that supports the power generation system; hence its cost will also be influenced by the design of the power generation and corresponding water ducting systems.

The cost drivers for platform moorings include spare components inventory, site conditions, weather, installation complexity, material costs, performance requirements, labor costs, water depth, regulatory permissions and decommissioning of mooring system. Though the current mooring technologies are adequate to estimate costs for the initial prototype plants, uncertainty in costs can increase as the plants begin to scale beyond 100 MW power output. The design of the platform-pipe interface will also influence the costs based on choice of materials, design and fabrication process, the cold water pipe and the platform.

The operating conditions of low temperature and pressure require design of heat exchangers which are good for moderate strength conditions, compared to the ones that are used in conventional power plants. This can lower the cost of installation and other supporting systems. Aluminum plate-fin heat exchangers have lesser transportation and integration costs compared to shell-and-tube stainless steel ones because brazened aluminum can be transported in standard shipping containers and assembled on site. The process of fabrication and deployment of the cold water pipe can significantly influence the installed capital cost of an OTEC plant. The typical trade-off is the cost associated with transporting the single pipe from some place on shore to the increased risks of failure due to multiple joints of a cold water pipe fabricated on location.

Deployment costs include costs for installing OTEC components which are either built and assembled onsite or fabricated offsite and deployed on location. The process would be heavily borrowed from the oil drilling industry. In the model where it is fabricated offsite, deployment would involve towing the OTEC structure using a barge and setting it up at a pre-designed location where the cold water pipe can then be assembled an/or installed.

The costs associated with turbines and pumps in an OTEC plant are predictable as the commercially available design of these components can be easily matched for OTEC applications. As turbines can be scaled modularly, the power output of the plant and the reliability requirements of power plant will influence the redundancy in the design of the power generation systems and hence, the costs of the system. The OTEC system will also require feed pumps and recycle pumps which are commercial available with a low acquisition cost but a significant maintenance cost. Finally, the energy transfer costs are influenced by the costs of the power cable system which depend on special equipment designed for unique local sea conditions and seafloor characteristics.

Figure 13: Proportion of costs in historical OTEC designs (n=20)

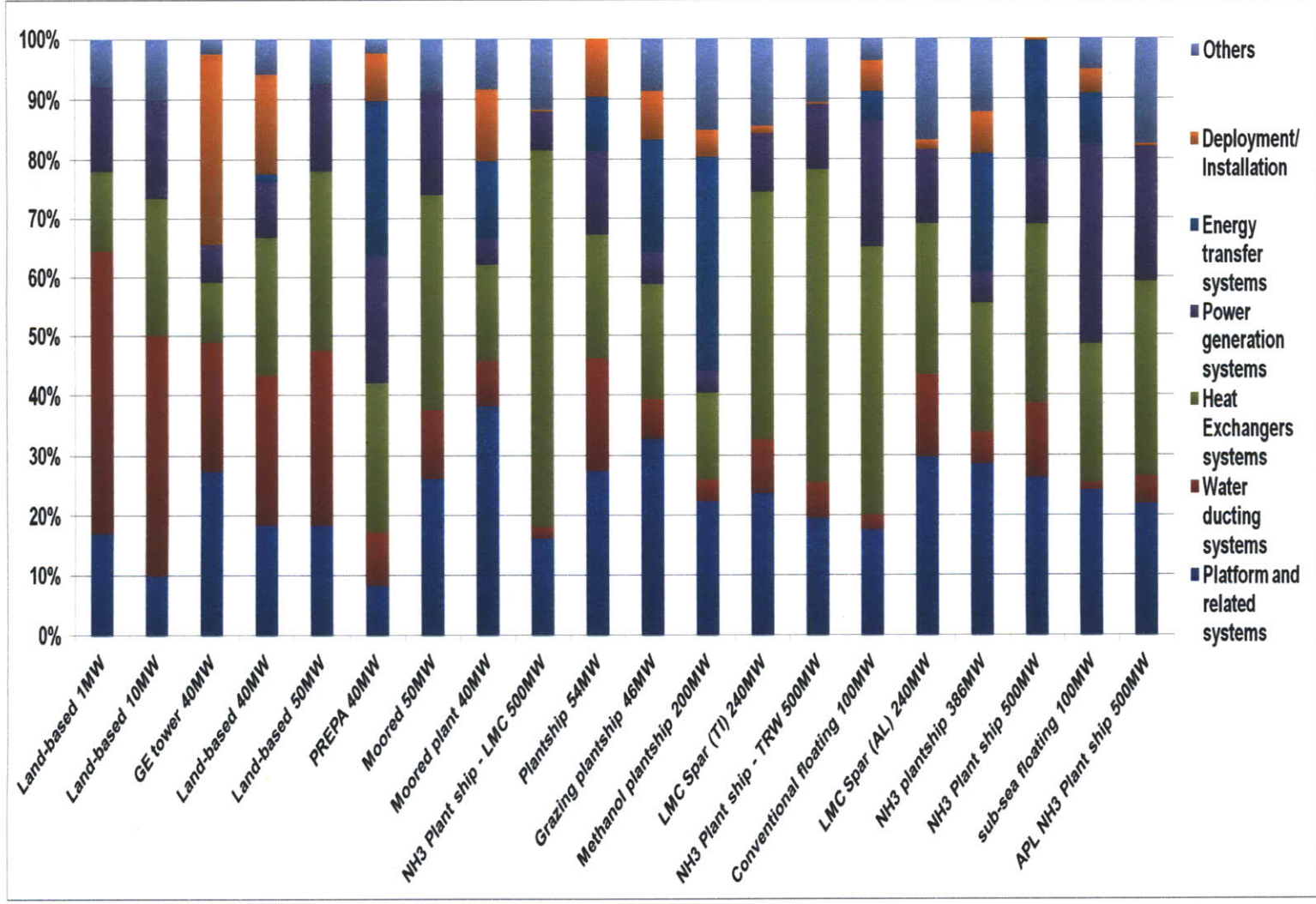

Table 4: Range of costs in OTEC plants (\$/kW installed)

Range of costs \$/kW installed	Water ducting	Platform	Power generation	Heat exchangers	Deployment	Energy transfer
Max	18942	6776	5698	5501	5250	3300
median	512	1436	707	1797	219	834
Min	30	530	184	586	13	202

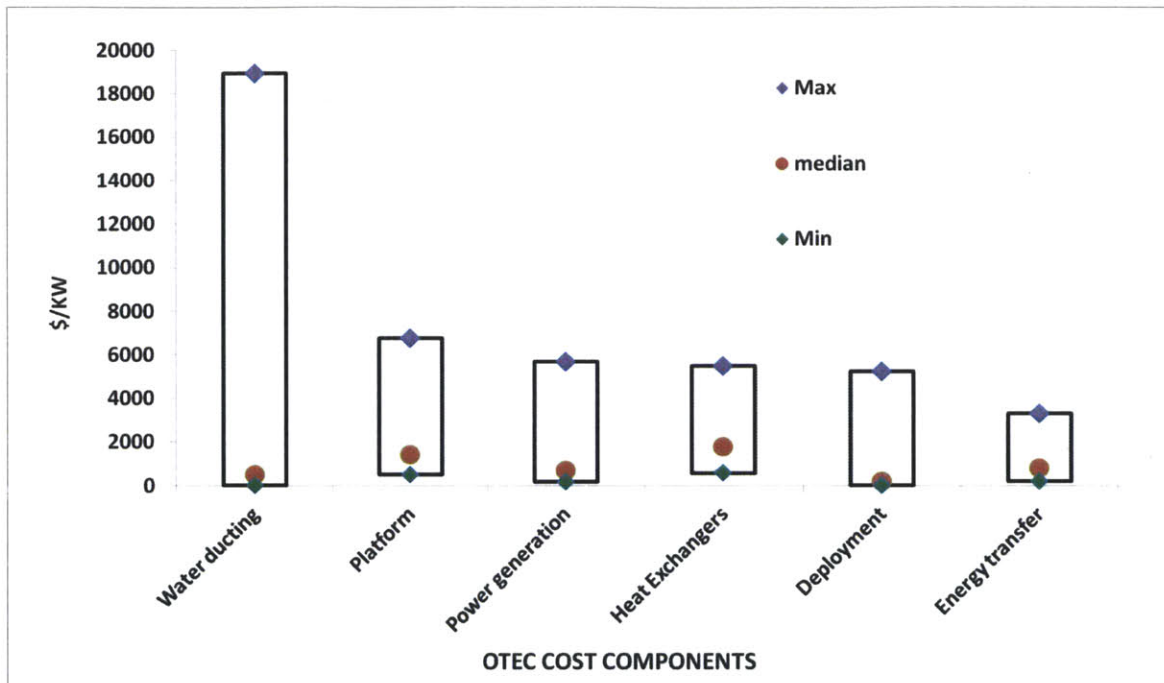

Figure 14: Range of costs of OTEC components (includes estimated from various plant sizes)

From the twenty-eight different cost evaluation models of OTEC plant, there were twenty for which the six cost drivers for the technology were available to be individually computed. The six major components' costs per kW and their range as a function of their cost contribution to the overall plant are given in [Figure 13]. This indicates platform structure and the heat exchangers are the major cost contributors to an OTEC installation cost. The cost of the platform will depend on the design configuration of the plant. The cost of heat exchangers per kW increases linearly with scale of the plant [18]. Preliminary studies of material used in OTEC platforms resulted in a design of concrete platforms over steel ones due to a thirty percent cost savings. Also, the most

cost-effective heat exchangers are made of aluminum. Among other costs, the most significant one is the cold water pipe where the cost per unit volume of handling cold water decreases with an increase in the cold water pipe diameter (up to a point, after which it increases). Conversely, deployment and operation and maintenance costs per kW do not increase significantly with increasing scale of the plant. [Table 4] and [Figure 14] show the variation in each of the cost components across all plant sizes. Water ducting systems have the most variation in prices and this is potentially an important lever for cost reduction, depending on the architecture of the OTEC system. Heat exchangers, though a large component of the cost, are products of standard and mature technologies borrowed from other industries and hence will be components designed and incorporated in the OTEC system with minimum design modifications from the ones used in these analogous industries.

4.3.1. Uncertainty in cost components

An initial set of uncertainty rules were designed as part of the early baseline designs of 40-MW floating and shore-based OTEC systems[3]. These uncertainty criteria applied for most of the OTEC components and resulted in an improved cost evaluation of OTEC systems. This facilitated a sensitivity analysis of several cost scenarios. Below, we compare the historically assigned uncertainties to costs with the results of our analysis

In that study[3], a low uncertainty of ± 10 -20% was allotted to components that can be readily used from analogous industries. These components usually use similar technology in another industry and hence require little or no modification to the component to be used in OTEC application. For large plantship producing ammonia and methanol, the percentage of costs covered in this category ranged between 45% and 70% of the total installed cost of the OTEC plant. In our analysis, the power generation systems and heat exchangers would qualify as components with low levels of cost uncertainties as the design of these components are readily applicable from other industries and require minimum or no customization for OTEC applications. The components' cost break-up graph [Figure 13] of our analysis shows that these components can contribute to 15% - 75% of the total component costs. This wide variation in costs is primarily contributed by the wide range in the heat exchanger costs from previous studies.

Also in that baseline design study, moderate uncertainties of $\pm 20\text{-}35\%$ were allocated to components which are available in a different scale/design than what is required for OTEC applications. These components had to be modified for OTEC applications. The percentage of component costs with these uncertainties is 41% and 23% for ammonia and methanol ships of the total installed cost of the plant. In our analysis, the platform-related systems and the energy transfer systems fall in this category because of the customization required on these components compared to designs for industries such as offshore oil drilling. Except for an initial design [Figure 7] where the platform-related costs were less than 10%, most of the newer designs account for platform costs upwards of 20% [Figure 13].

In the baseline design study[3], high uncertainties of $\pm 35\text{-}100\%$ were allotted to components that had to be uniquely fabricated for OTEC applications. The deployment of the cold water pipe and any component that requires OTEC-specific fabrication fall into this category. Fortunately, components with such high uncertainty form only 13% and 7% of the total installed costs. In our analysis, the water ducting costs fall under this category. Our findings are consistent with these uncertainty percentages as the water ducting systems seem to have the largest range of costs depending on plant size and location. Our study [Figure 13] shows that the water ducting system costs as a percentage of overall costs of the plant reduces with the scale of the plant. It is as high as 50% in the 1-10 MW category of plants and reduces significantly to less than 10% in the >100 MW plant sizes.

Finally, the study [3] calculated the uncertainty of the overall system using the weighted average of risks of components in the high, medium and low uncertainty categories, and included variation in construction and deployment costs as well. The overall uncertainty of the OTEC system costs, thus derived, was estimated to be between 20% and 30%.

4.4. Comparison of OTEC with other energy technologies

4.4.1. Levelized cost of energy

The US Energy Information Administration (EIA) produces forecasts of energy supply and demand for the next 20 years using the National Energy Modeling System (NEMS)[30]. One of the parameters that the EIA calculates using NEMS is the levelized cost of energy (LCOE). Levelized costs of energy represent the present value of the total cost of building and operating a

plant over its financial life, converted to equal annual payments and amortized over expected annual generation from an assumed duty cycle. The LCOE is a standard way to determine the most economic technology to adopt for new capacity, for base load¹⁷, peaking load¹⁸ or intermediate load¹⁹.

The DOE-approved LCOE methodology requires minimum system cost information and avoids many of the complications involved in calculating the actual cost to deliver electricity to a particular end user. Because the LCOE includes the capacity factor of each technology some technologies, such as a conventional combined cycle turbine, which are relatively expensive at a high capacity factor due to high fuel costs, may be the most economic option when evaluated at a lower capacity factor. A lower capacity factor would be associated with an intermediate or peaking load rather than a base load facility.

Usually, the LCOE calculation does not include financial incentives such as state or federal tax credits, which can impact the cost and the competitiveness of the technology. These incentives, however, are incorporated into the evaluation of the technologies in NEMS based on current laws and regulations in effect at the time of the modeling exercise. Also due to regional differences in the cost of labor, fuel, and other factors that affect the levelized generation cost, there exists a range of levelized costs for any energy technology with a minimum, maximum and average of that range used for calculation purposes.

4.4.2. Comparison of capital cost and O&M costs

This study utilizes the findings of an Life Cycle Cost Analysis Study [28] which calculated the levelized cost of electricity generated by three different sizes and configurations of OTEC plants - 100 MW, 200 MW and 400 MW net electrical power output plants where the electricity is cabled to shore via marine power cable. This is used to compare with competing renewable energy systems to evaluate the financial viability of OTEC technology. These costs, and the others cited in this thesis, are cost projections rather than cost data from existing plants.

¹⁷ Base load plants are facilities that operate almost continuously usually at annual utilization of 70% or higher

¹⁸ Peaking plants are facilities that only run when the demand for electricity is very high, usually at annual utilization of less than 25%

¹⁹ Intermediate load plants are facilities that operate less frequently than base load plants, usually at annual utilization between 25 -70%

There are three parameters that were derived from the findings of the study, to be compared with the other energy technologies in the EIA Annual Energy Outlook 2009 [30]. They are the levelized capital costs, the levelized O&M costs and the levelized cost of energy, all in \$/MWh.

Our study utilized the Initial Capital Cost (ICC) of OTEC plants to arrive at the levelized capital costs. ICC is the total overnight²⁰ cost to build and install the plant including the mooring system and undersea power cable as well as program management for the deployment. These costs do not include construction financing or financing fees and do not take the length of the construction period into account. For consistency across all plant sizes and with the capital costs used earlier in this study, the ICC was estimated in 2010 \$ from the original values which were calculated for different years of deployment [31].

$$\text{Levelized capital costs } \left(\frac{\$}{\text{MWh}} \right) = \frac{\text{Annualized capital costs } \left(\frac{\$}{\text{year}} \right)}{\text{Capacity factor} \times \text{No. of hours per year}}$$

Where Annualized capital cost = ICC × CRF (\$/years)

$$\text{CRF} = \frac{r(1+r)^n}{(1+r)^n - 1} \text{ where } r = \text{weighted average cost of capital} = 7.4\%^{21}$$

n = Lifetime of the plant (years) = 30

Capacity factor = 95% to 97% based on the size of the plant

No. of hours per year = 365 × 24 = 8760

Similarly, the levelized Operations and maintenance (O&M) costs for the OTEC plants were derived for the OTEC plants using the equation:

$$\text{Levelized O\&M costs } \left(\frac{\$}{\text{MWh}} \right) = \frac{\text{Annualized O\&M costs } \left(\frac{\$}{\text{year}} \right)}{\text{Capacity factor} \times \text{No. of hours per year}}$$

The major cost components of the O&M costs included in the study were equipment maintenance/overhaul costs, spares costs, Packing, handling, storage and transportation, program

²⁰ The capital cost of a project if it could be constructed overnight and does not include the interest cost of funds used during construction of the project.

²¹ US EIA Levelized Cost of New Generation calculations http://www.eia.gov/oiaf/aeo/electricity_generation.html

management, personnel costs, training, crew transport, ongoing environmental monitoring costs, disposal costs and safety costs.

Once the levelized capital costs and levelized O&M costs were calculated, levelized cost of energy (LCOE) was calculated as

$$\text{LCOE (\$/MWh)} = \text{levelized capital costs} + \text{levelized O\&M costs}$$

Once the LCOE was calculated for various plant sizes, the average LCOE was calculated as the weighted average of the LCOE of the three different plant sizes.

Table 5: Levelized cost calculations of various sizes of OTEC plants

OTEC plant size (MW)	100	200	400
Capacity factor	95%	96%	97%
2010 Initial capital cost (\$) [28]	1,389,098,117	2,219,524,281	3,473,736,373
Lifetime (years)	30	30	30
WACC (%)	7.4%	7.4%	7.4%
Capital Recovery Factor	0.084	0.084	0.084
Annualized capital cost (\$/year)	116,473,678	186,103,597	291,267,296
Levelized capital costs (\$/MWh)	140	111	86
Annualized O&M costs (\$/year) [32]	44,802,606	75,475,182	124,200,366
Levelized O&M costs (\$/MWh)	54	45	37
LCOE (\$/MWh)	193.80	155.52	122.24
Average LCOE (\$/MWh)	142.0		

After the levelized costs are calculated, they are analyzed and compared with those of competing technologies.

OTEC has a very high capital costs due to the high cost of components that make up installation costs of a typical OTEC project. For a 100 MW grid-connected OTEC plant, the levelized capital cost is at 140\$/MWh which is much higher than most conventional energy technologies except offshore wind, solar PV and solar thermal [Figure 15]. The capital costs of OTEC plants decrease with an increase in the scale of the power output and reduces to 111\$/MWh for a 200 MW grid-connected plant and to 86\$/MWh for a 400 MW grid-connected plant. This is a decrease of 21%

from doubling of power output from 100 MW to 200 MW and 23% decrease for the power output doubling from 200 MW to 400 MW. This limited information shows an average 22% reduction in capital costs for doubling of power output. This is roughly the same factor of reduction as found in our analysis of construction cost calculations of OTEC plants, which also shows a decrease of 22% in the cost/installed kW for each doubling of output.

This reduction becomes more significant in the context of the high availability of OTEC plants. OTEC plants are assumed to have a very capacity factor of 95% to 97% in the 100MW – 400 MW range[28]. It has the highest capacity factor among all competing renewable technologies, comparable with other base load technologies such as conventional coal and natural gas plants. While the high capacity factor for OTEC has been assumed in cost projections, it is important to study this variable in fully operational prototypes or demonstration plants. Currently, the high capacity factor makes OTEC an attractive candidate for markets which require a technology with high availability qualities to supply base load power. For coastal regions in the OTEC belt with a good transmission network, a careful consideration of this technology is warranted, alongside discussions regarding other technologies such as offshore wind or solar.

Table 6: Capacity Factor and levelized costs of various technologies

Plant Type	Capacity factor (%)	Levelized capital costs (\$/MWh)
Solar Thermal	18	259
Solar PV²²	25	195
Wind	34	84
Wind - Offshore	34	209
Hydro	52	75
Biomass	83	55
Conventional Coal	85	65
Advanced coal	85	75
Advanced coal with CCS²³	85	93
NG²⁴ Advanced CC²⁵	87	18
NG CC	87	18
NG Advanced CC with CCS	87	35
Advanced Nuclear	90	90
Geothermal	92	79
OTEC 100 MW	95	140
OTEC 200 MW	96	111
OTEC 400 MW	97	86

Source: [30]

²² Photo-Voltaic

²³ Carbon Capture and Sequestration

²⁴ Natural Gas

²⁵ Combined Cycle

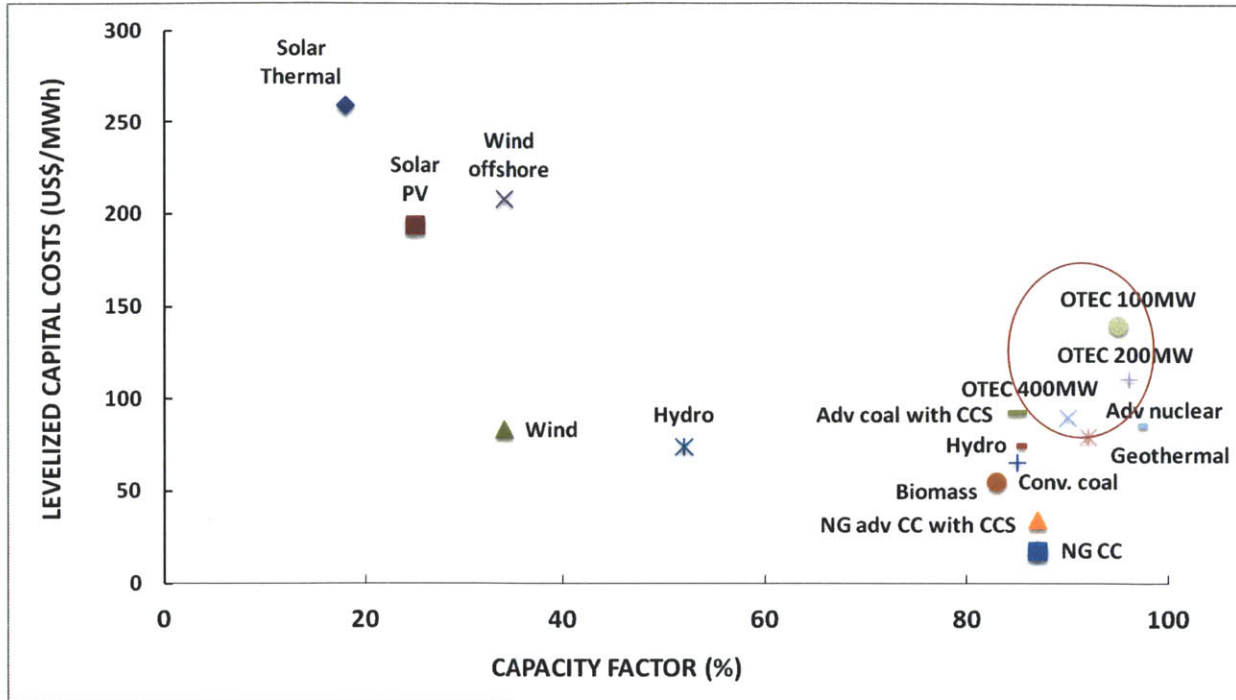

Figure 15: Levelized capital costs vs. capacity factor for various energy technologies

Also, levelized O&M costs of OTEC are compared with the same costs of other technologies to identify the operational cost commitment of OTEC plants relative to other technologies throughout the lifetime of the plant. Levelized O&M costs are equal to the O&M costs calculated for the first year, followed by the replacement/overhaul costs levelized through assessment of the present value, and application of a capital recovery factor to each replacement/overhaul activity. In the lifecycle cost assessment study[28], the operations and sustainment (O&S) model was used to estimate costs incurred after initial deployment which provides all O&S costs on a yearly basis and hence merges the annual O&M costs with the occasional replacement/overhaul Costs to derive a single levelized O&M cost. To compare with equivalent O&M costs of competing energy technologies in the US Energy Information Administration (EIA) Annual Energy Outlook 2011 report[30], the levelized fixed and variable O&M costs (which includes fuel cost) of the various energy technologies were combined to derive uniform levelized O&M cost for all technologies.

For OTEC, levelized O&M costs average at about 29% of the levelized initial capital cost. This is much higher compared to other technologies such as hydro, wind and solar which are in the

range of 6% to 18% of their levelized initial capital costs, but much lower than some of the fossil fuel technologies such as natural gas, which can be more than 100% of their levelized initial capital cost. This is because the conventional technologies utilize fuel and the fuel bill is a part of their variable O&M costs. Compared to this, OTEC has no fuel cost and therefore has an advantage over conventional power plants [Figure 16]. Most of the overhaul and replacement procedures associated with OTEC plants are standard procedures that can heavily borrow from other industries such as oil offshore plants. Of course, components such as the cold water pipe might still pose serious maintenance challenges and will be the key to the keeping the maintenance costs of this technology down.

Table 7: Levelized capital costs and O&M costs of various plant types

Plant Type	Levelized capital costs (\$/MWh)	Levelized O&M (\$/MWh)
NG CC	18	47.5
NG Advanced CC	18	44.0
NG Advanced CC with CCS	35	53.5
Biomass	55	56.0
Conventional Coal	65	28.2
Hydro	75	10.1
Adv. coal	75	33.6
Geothermal	79	21.4
Wind	84	9.6
Advanced Nuclear	90	22.8
Advanced coal with CCS	93	42.3
Solar PV	195	12.0
Wind - Offshore	209	28.1
Solar Thermal	259	46.6
OTEC 400 MW	86	39.8
OTEC 200 MW	111	44.9
OTEC 100 MW	140	53.8

Source: http://205.254.135.24/oiaf/aeo/electricity_generation.html accessed on Feb 4, 2012

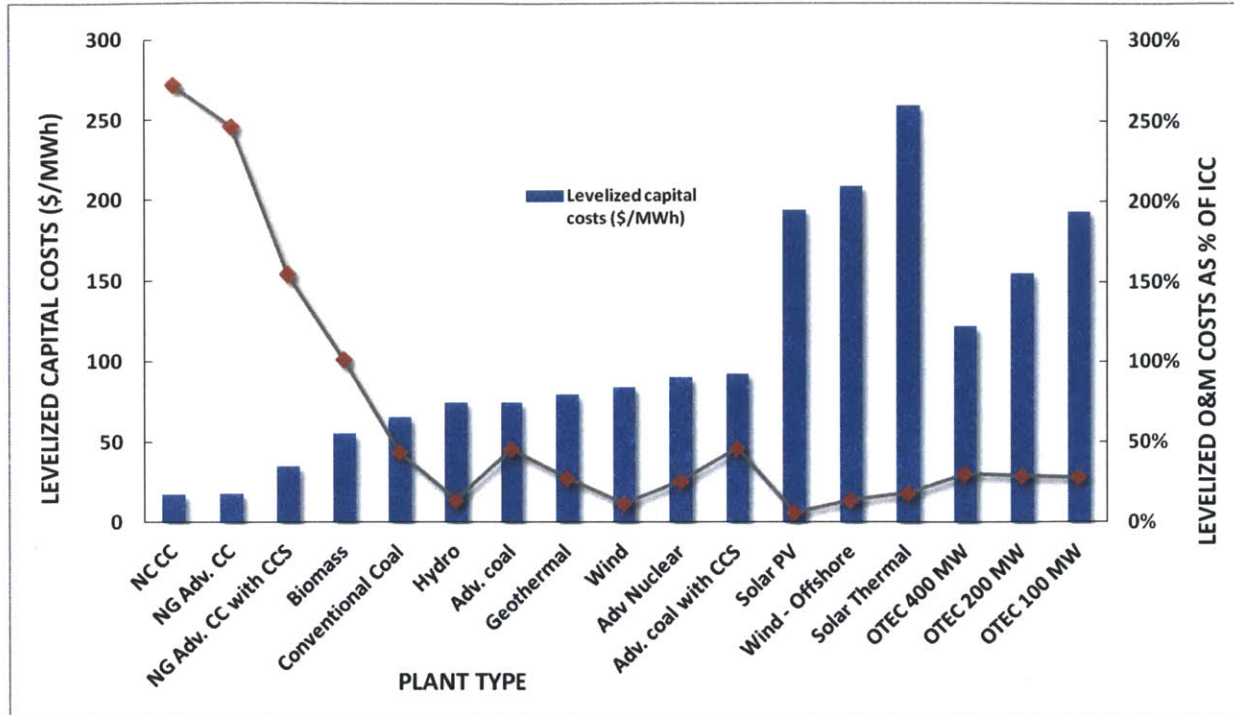

Source: http://205.254.135.24/oiaf/aeo/electricity_generation.html accessed on Feb 4, 2012

Figure 16: Comparison of levelized capital costs and O&M costs of energy technologies

At 40\$/MWh for the 400 MW OTEC configuration, the levelized OTEC O&M cost is below the levelized O&M costs for several of the competing conventional and renewable technologies. This figure gains further significance in the context of the 30-year lifetime that OTEC plants are designed for. The other technologies in the study have an average lifetime of 25 years. (We note, however, that currently operating power plants often have longer lifetimes in reality. This could serve to decrease the electricity costs for certain plants, as compared to the estimates shown above.) There have also been recent studies that discuss the possibility of extending the 30-year lifetime of OTEC plants. This also supports the case for OTEC as a base load electricity generator, and a long-term energy solution for a community.

Finally, when we compare the LCOE of OTEC with that of other technologies, we see that average LCOE of OTEC (142 \$/MWh) is higher than that of most conventional technologies

[Figure 17]²⁶. The high levelized capital cost of OTEC is the main contributor for this high value. But the average value is still projected to be less than that of some renewable technologies such as offshore wind, solar PV and solar thermal. The LCOE of these competing technologies also show a wider variation in the range between maximum and minimum values, than that projected for OTEC. For example, solar thermal with an average LCOE of 312 \$/MWh has a wide variation from 60% of this average value to more than 200% at the maximum. Compared to this, OTEC has an average LCOE (142\$/MWh) which is within 20% of the minimum value (122\$/MWh) and 40% of the maximum value (194\$/MWh). This smaller range can indicate a greater stability in the cost drivers of OTEC components across regions and scale of power output. If this holds in real plants, the consistency in costs for OTEC plants in different markets around the world could help make a case for this technology. Also, at only 60% of the LCOE of offshore wind, OTEC has a definite advantage in coastal locations falling within the OTEC resource zones. This difference can be significant when considering challenges such as transmitting power from some distant offshore farms or the much lower capacity factor of offshore wind farms are included. However we note again that the cost estimates presented here for OTEC are projections rather than cost data as in the case of wind and solar. Nonetheless, the above levelized cost discussions indicate that OTEC, though not an inexpensive technology, should be a serious contender when siting new base load power generation or planning for new renewable generation, once the locations and technical considerations are met for the technology.

²⁶ Note that this estimate of OTEC costs is from our analysis and the other technologies are from the LCOE estimates from the EIA Annual Energy outlook report. However the estimated costs are comparable.

Table 8: Range of LCOE for various energy technologies

Plant Type	Max. LCOE (\$/MWh)	Min. LCOE (\$/MWh)	Avg. LCOE (\$/MWh)
NG Advanced CC	70.5	56.9	63.1
NC CC	74.1	60.0	66.1
Hydro	121.4	58.5	86.4
NG Advanced CC with CCS	104.0	80.8	89.3
Conventional Coal	110.8	85.5	94.8
Wind	115.0	81.9	97.0
Geothermal	115.7	91.8	101.7
Advanced coal	122.1	100.7	109.4
Biomass	133.4	99.5	112.5
Advanced Nuclear	121.4	109.7	113.9
Advanced coal with CCS	154.5	126.3	136.2
OTEC grid-connected	193.8	122.2	142.0
Solar PV	323.9	157.7	210.7
Wind - Offshore	349.4	186.7	243.2
Solar Thermal	641.6	191.7	311.8

Source: http://205.254.135.24/oiaf/aeo/electricity_generation.html accessed on Feb 4, 2012

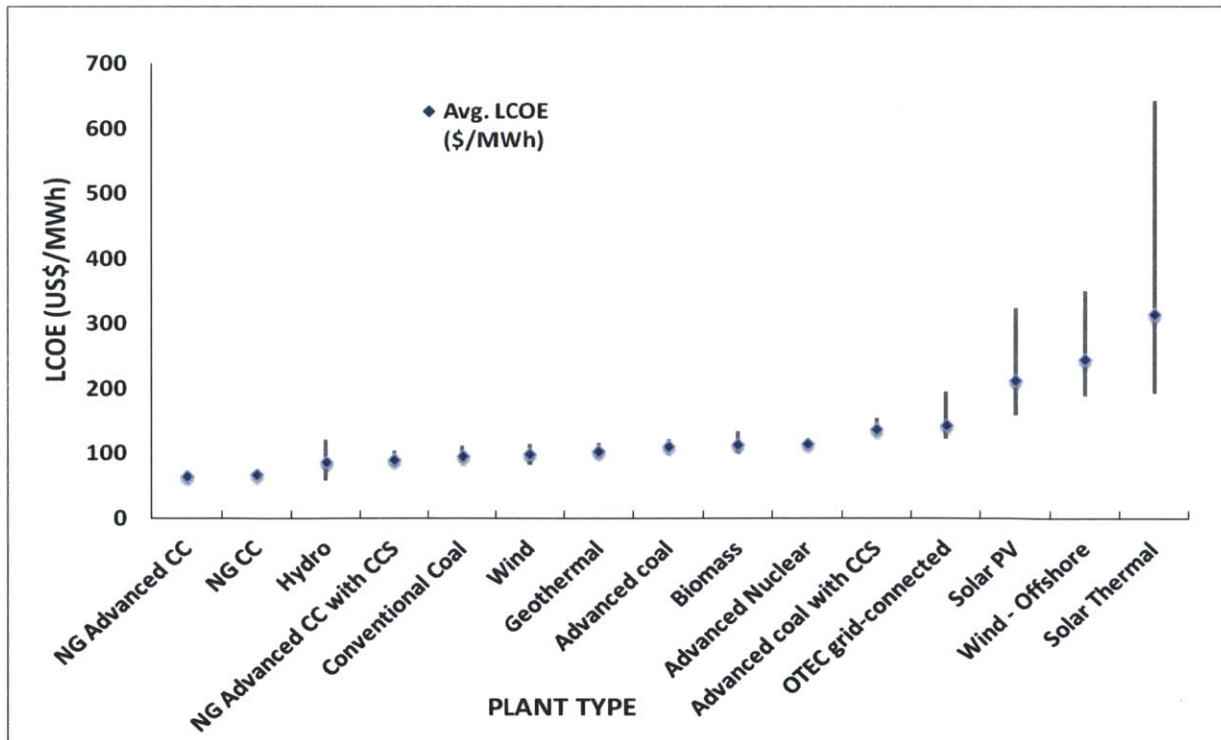

Figure 17: Average LCOE for energy technologies within a range of max. and min. values

5. OTEC AND WATER SCARCITY

In 2011, the increase in population to more than 7 billion translated into double the water consumption in the last half century and between 1970 and 1990, per capital of available water decreased by a third. An increasing demand for water for drinking water supplies, sanitation, agriculture, energy production and generation, mining and industry is expected to compete for a limited supply of fresh water. By 2025, more than half the nations in the world will face freshwater stress or shortages and by 2050 as much as 75% of the world's population could face freshwater scarcity[6]. Regions with intensive agriculture and dense population as the Asia, Africa and the US have high threat to water security. According to the US Natural Resources Defense Council[33], more than one-third of all counties in the lower 48 states of the US will likely be facing very serious water shortages by 2050.

Though water is a renewable resource, only 2.5% of earth's water is potable, and almost two-thirds of that is locked up in glaciers and permanent snow cover. The Earth has a limited supply of fresh water in the form of aquifers, surface waters and the atmosphere. Oceans are an abundant supply of water but the amount of energy needed to convert seawater to water for human use is expensive today, explaining why only a very small fraction of the world's water supply derives from desalination²⁷.

5.1.Introduction to seawater desalination

The most popular desalination technologies used on seawater an industrial scale are:

- Multi-stage flash (MSF)
- Multiple Effect distillation (MED)
- Mechanical Vapor Compression (MVC)
- Reverse Osmosis (RO)

Of all the above technologies, MSF was the most prevalent method used for desalination but in recent years RO has been catching up because of its ability to scale-up modularly for large

²⁷ Desalination refers to any of several processes that remove some amount of salt and other minerals from saline water

capacities. Studies have estimated the typical capacities and corresponding costs for the various technologies [34].

Table 9: Average Capacities and costs for seawater desalination technologies

Desalination technology	Typical Average Capacity (MGallons²⁸/day)	Cost (\$/kGallon)
MSF	6.6	4.16
MED	2.6	3.03
VC	0.8	2.65
RO	1.6	2.65

Source: [34]

Though the installation of MSF reduced in the previous decades and RO has begun to compete in seawater desalination markets, MSF still is preferred over RO due to reliability of the plants, ease of operation and very low degradation of performance over a long duration of the life of the facility[35]. As the MSF technology for desalination is very expensive compared to other technologies, it primarily has been popular in regions such as the middle-east where the cost of energy for the process is really low. The limited diffusion of MSF in the recent years has been due to challenges in installing a source of electricity supply at the site of freshwater production, including the logistics of managing two separate plants and the environmental impact of fossil fuels used in these plants [36].

To reduce the carbon impact of the process, there has been an interest in recent years, either to reduce energy requirements for desalination or to replace conventional energy sources with renewable ones [37]. Though these methods have been recommended for remote, arid and island settings, the high-cost of installing conventional renewables usually leads to unfavorable economics of the technology.

OTEC can step in as the technology which can provide integrated clean and sustainable solutions with large-scale desalination options with electricity generation catering to small- and medium-sized communities which are both energy- and water-constrained.

²⁸ MGallons – Million Gallons

5.2. OTEC and Desalination

Sustainable supply of freshwater in the future will depend on using innovative alternative technologies such as advanced membrane-separation technologies in non-traditional water sources including waste water, brackish groundwater and extracted mine water to increase the 'water capital' in inland regions. But coastal regions and regions not too far from the coast, where a freshwater distribution network is already established, can utilize OTEC to extract freshwater water from the ocean. In addition to electricity generation, an OC-OTEC plant produces freshwater as a by-product of the power generation process. When the cold deep ocean water condenses the vapor from the warm water stream through heat exchangers, freshwater is produced, leaving the salt behind in the warm water stream. This water is completely free of salt and suitable for most agricultural, commercial, industrial and domestic uses.

Desalinated water may play an important role in the future of OTEC technology commercialization. Several analyses outline a scenario in which commercial OTEC plants ranging from 1MW to 10 MW, that are land-based open-cycle or hybrid systems, use the production of desalinated water to offset the cost of electricity generated by the system. Previous OTEC literature [10] states that commercialization confidence of the integrated electricity-desalination plant will set in if demonstrated with a prototype generating at least 1 MW of electric power and producing 3,500 cubic meters of desalinated water per day. Water supply purification and alternative desalination technologies used in combination with energy production technologies may be able to offset the costs discussed earlier in this study.

Fresh water can be obtained from the evaporated warm seawater used either as the working fluid in the Open-Cycle OTEC power production process or as the additional working fluid in a Kalina Cycle thermodynamic process. The Kalina cycle uses a mixture of water and ammonia as a working fluid for low delta T heat and has been commercially used for more than two decades [25]. In 2003, high-quality fresh water high with 80 mg/l (approx.) of TDS²⁹ was produced from

²⁹ Total Dissolved Solids

an Open-Cycle OTEC at a functioning plant at NELHA³⁰ but still required more work to adjust the pH to control acidity and dissolved oxygen to improve the taste.

5.3. A study of water scarcity metrics

Measuring water scarcity has evolved significantly in the past several decades. The first water scarcity metric developed by Falkenmark [38] was an important foundation on which further water demand models were built. The water scarcity index model was further refined by Gleick [39] incorporating specific water requirements for basic human needs. Water as an important metric for ecological sustainability based on increased domestic water withdrawals and demands led to several approaches to the scarcity problem [40–43]. Recently, the damages caused by water consumption were evaluated [44] followed by the proposition to measure water stress of an area based on ecological quality. One of the holistic methods to measure water stress and scarcity incorporating industrial, ecological and socio-economic factors has been using water foot-printing method proposed by calculating the respective blue, green, and grey water footprints [45]. This method was then followed by alternative method of the Water Stress Index [46] which improved the water foot-printing method to compare footprints of several different sectors, regions, products, etc.

The following section offers a review of the four methods that offers the most value to identify water-stressed and water scarce regions of the world so that these regions can be mapped with OTEC resource maps of the world to assessment possibilities of integrated electricity-freshwater generation using OC-OTEC configurations.

³⁰ Natural Energy Laboratory of Hawaii

5.3.1. Water Stress Indicator (WSI)

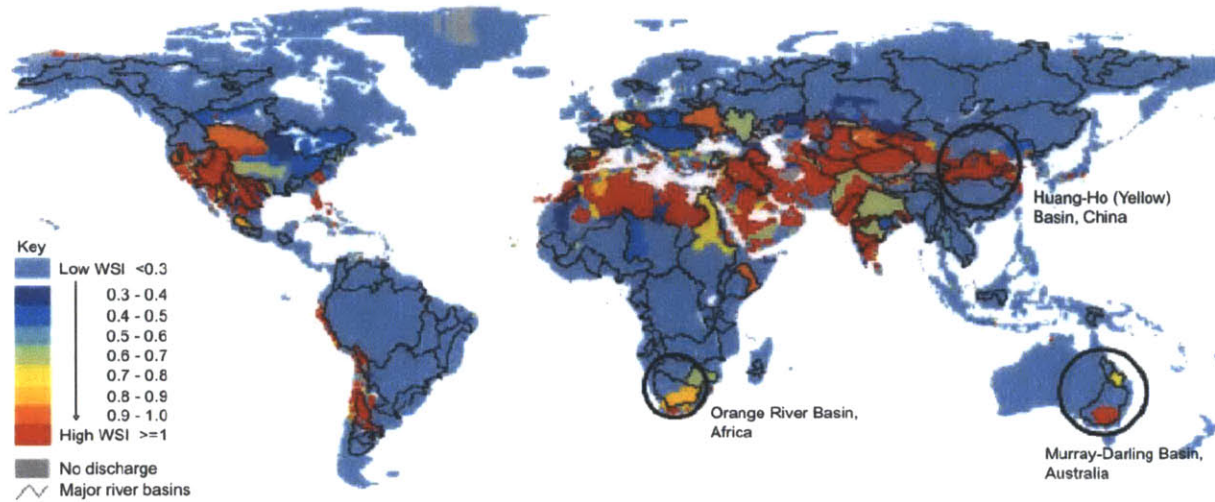

Source: [47]

Figure 18: Global map of WSI taking into account EWR

The above Water Stress Indicator (WSI) was developed by Smakhtin [47], [48]. It recognizes the relationship between environmental water requirements (EWR), water availability and total withdrawals. Mean annual runoff (MAR) is used to calculate total water availability, and estimated environmental water requirements (EWR) are expressed as a percentage of long-term mean annual river runoff that should be reserved for environmental purposes. Using global annual water withdrawal data from IWMI³¹ for industrial, agricultural, and domestic sectors, global water resources incorporating environmental water requirements were evaluated using the following categories and the equation

$$WSI = \frac{\text{Withdrawals}}{\text{MAR} - \text{EWR}}$$

Categorization of environmental water scarcity

WSI (proportion) Degrees of Environmental Water Scarcity of River Basins

- **WSI > 1** - Overexploited (current water use is tapping into EWR)—environmentally water scarce basins.

³¹ International Water Management Institute

- $0.6 \leq \text{WSI} < 1$ - Heavily exploited (0 to 40% of the utilizable water is still available in a basin before EWR are in conflict with other uses)—environmentally water stressed basins.
- $0.3 \leq \text{WSI} < 0.6$ - Moderately exploited (40% to 70% of the utilizable water is still available in a basin before EWR are in conflict with other uses).
- $\text{WSI} < 0.3$ - Slightly exploited

5.3.2. Physical and economic water scarcity

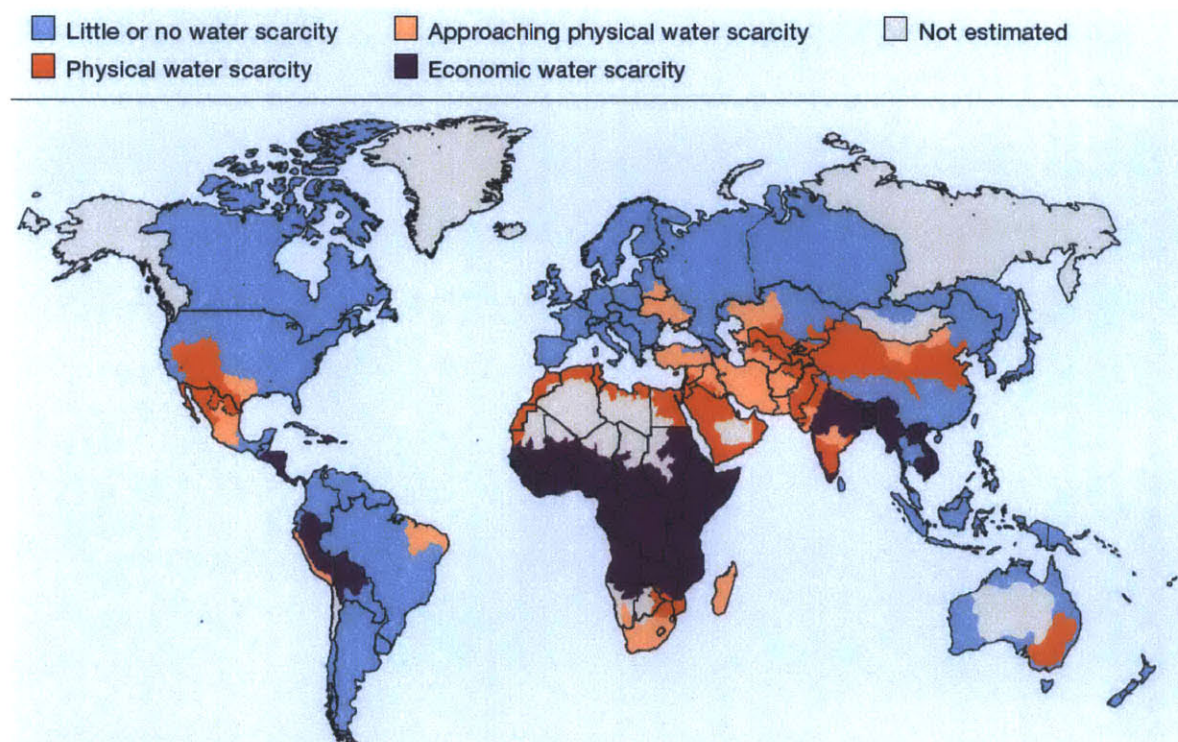

Source: [49]

Figure 19: Global map of physical and economic water scarcity

The IWMI subsequently used a water scarcity assessment on a large-scale across the world. They conducted an analysis that considered the portion of renewable freshwater resources available for human requirements (accounting for existing water infrastructure), with respect to the main water supply. The analysis labeled countries with

- **None or little water scarcity:** Abundant water resources relative to use; less than 25% of water from rivers is withdrawn for human purposes
- **Physical water scarcity:** more than 75% of river flows are withdrawn for agriculture, industry, and domestic purposes. This implies that dry areas are not necessarily water scarce. Indicators of physical water scarcity include: acute environmental degradation, diminishing groundwater, and water allocations that support some sectors over others [49]
- **Approaching physical water scarcity:** More than 60% of river flows are allocated. These basins will experience physical water scarcity in the near future.
- **Economical water scarcity:** Countries having adequate renewable resources with less than 25% of water from rivers withdrawn for human purposes, but needing to make significant improvements in existing water infrastructure to make such resources available for use [50].

5.3.3. Water Poverty Index

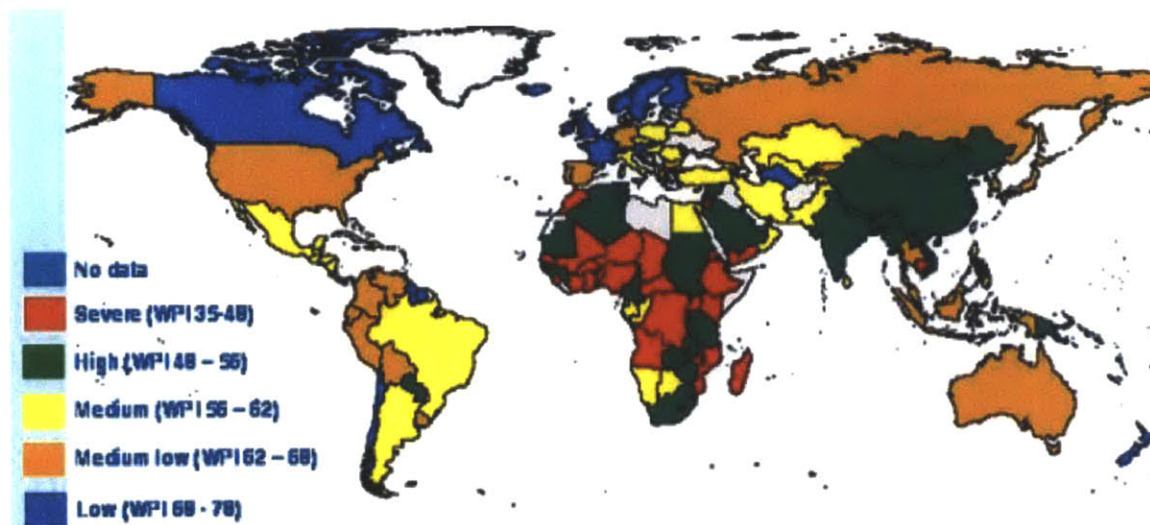

Source:[40]

Figure 20: Global map of water poverty index

Sullivan [40] noted that depleted freshwater resources are linked to ecosystem degradation, and therefore, any index of water poverty should include the condition of ecosystems that maintain sustainable levels of water availability. Using a comparable methodology to that of the Human Development Index, a water poverty index was constructed which measures countries' position

relatively to each other in the provision of water. The water poverty index incorporates ecosystem productivity, community, human health, and economic welfare, each with several sub-components. Corresponding to the conceptual framework discussed above, the main components are:

- Resources
- Access
- Capacity
- Use
- Environment

The basic calculation, except where indicated below, is based on the following formula:

$$WPI = \frac{X_i - X_{min}}{X_{max} - X_{min}}$$

where X_i , X_{max} and X_{min} are the original values for country i , the highest value country, and the lowest value country respectively. The indices therefore show a country's relative position and for any one indicator this lies between 0 and 1. The maximum and minimum values are usually adjusted so as to avoid values of more than 1. Any remaining values above 1 or below zero are fixed at 1 and 0 respectively. However, this approach is critically dependent on the development of standardized weights to be applied to each of the variables previously mentioned. The problem therein lies with the basis of these weights as well as the assumption that the weights hold true for all ecosystems, communities, economics, and cultures.

5.3.4. Water foot printing

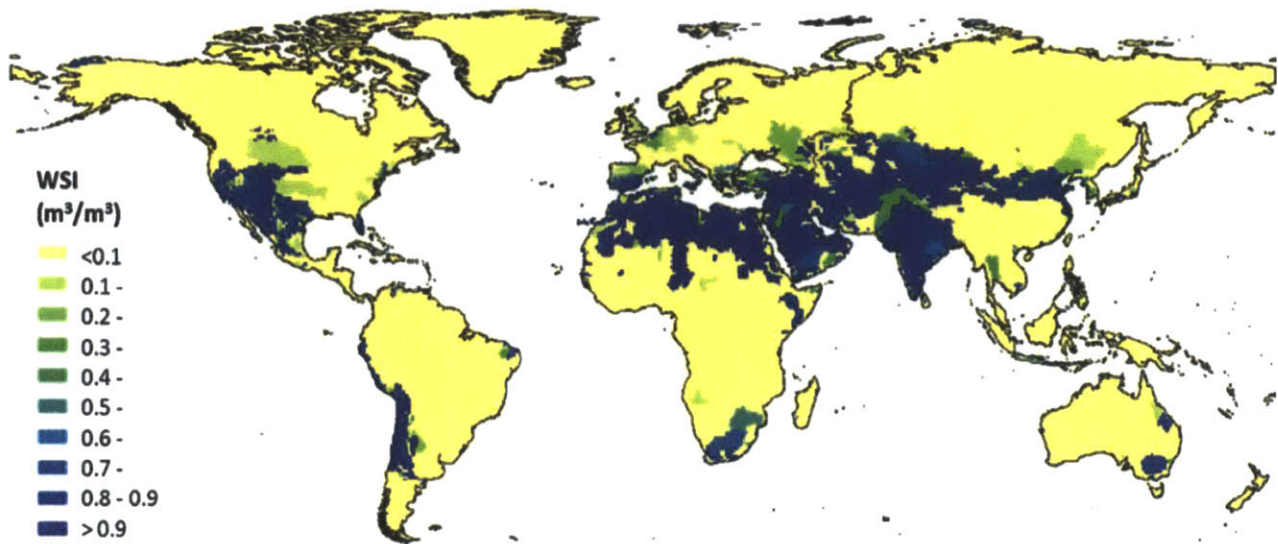

Source: [46]

Figure 21: Global map of water stress index

Pfister [44] utilized the WSI as a general screening factor for water consumption used in Life Cycle Impact Assessment (LCIA) to measure how water use are related to potential environmental damages in three areas: human health, ecosystem quality, and resources.

Withdrawal to Availability (WTA) ratio is given by the equation:

$$WTA_i = \frac{\sum_j WU_{ij}}{WA_{ij}}$$

The WTA is initially calculated for each watershed i , which is the fraction of available water (WA) used (WU) by each sector j . Moderate and severe water stress occur above the respective thresholds of 20% and 40%, commonly known as the critical ratio [51]. A weighting factor is applied to the WTA calculated for each watershed in order to account for variations in monthly or annual flows. The weighted WTA is then expressed as WTA and the WSI is calculated as:

$$WSI = \frac{1}{[1 + e^{-6.4WTA + (\frac{1}{.01} - 1)}]}$$

WSI is based on the WaterGAP2 global hydrological and global water use models [52] with modifications to account for monthly and annual variability of precipitation and corrections to account for watersheds with strongly regulated flows. The index follows a logistic function ranging from 0.01 to 1. It is tuned to result in a WSI of 0.5 for a WTA ratio of 0.4, which is commonly referred to as the threshold between moderate and severe water stress [41] [51].

The WSI has a spatial resolution of 0.5 degrees which is more relevant to describing water stress at a local watershed level than indicators which are based on national or per capita statistics[53]. Especially for large, heterogeneous countries like Australia, China, India and the US, national statistics provide little insight into local water scarcity.

5.4.Freshwater from OTEC

The discussion of water scarcity indices is useful when identifying new markets for OTEC plants. Several countries in the original list of ninety-eight countries[19] which are within the OTEC resource belt are developing nations where setting up a capital-intensive base load electricity generation option might be a difficult economic imperative. But these countries can consider capital investment if they are able to extract more value from the OTEC investment in addition to generation of electricity. Hence the water scarcity indices might help narrow down a list of countries which are in the OTEC zone and have a problem of water scarcity in addition to constraints in electricity generation.

When the global plots of water stress and the OTEC-friendly resource regions are mapped over one another, the following regions can be short-listed as potential locations for co-production of electricity and fresh water:

- East coast of Mexico adjoining the Gulf of Mexico including some of the islands to the east of Mexico, the southwest coastal regions of Mexico along the Gulf of California.
- Coastal regions in the Caribbean Sea along the countries of Guatemala, Honduras, El Salvador, Nicaragua, Costa Rica, Panama, Dominican Republic and Puerto Rico.

- In the north Atlantic Ocean, the northern coast of Brazil and the northwestern African countries of Guinea, Sierra Leone, Liberia
- Regions along the Arabian Sea and the Bay of Bengal in the southern peninsula of India, Burma (Myanmar), Thailand East coast of Africa in the states of Somalia, Tanzania and Mozambique and the island of Madagascar in the Indian Ocean.

Several of these locations in the “overlapping” list are Developing/Small Island Nations across the world. For several island nations across the world, water resources are quite restricted. This limits the economic development of the local communities. Tropical islands that qualify with requisite OTEC temperature differential and depth criteria are excellent markets for OTEC plants as this solution will meet their need for both base-load electric power and freshwater,. There are several other islands which satisfy these criteria and are good candidates for co-locating the generation of both these essential utilities. This technology has the potential to provide a solution for communities with increased potable water requirements where desalination of existing aquifers cannot meet demand and the unviable economics prevent import of large quantities from the nearest mainland.

The following is a case-study of the Bahamas with purpose to examine the economic viability of a typical open-cycle OTEC configuration integrating electricity generation and desalination plant using an integrated break-even analysis. The obtained results captures two conditions: one, arriving at the viable busbar price of selling freshwater using the OTEC plant, given that electricity is sold at prevailing market price and the other, arriving at the viable price of selling electricity using OTEC plant, given that freshwater is sold at market price (which is the equivalent current purchase price of water from RO sources). This analysis does not include other benefits of integrating these two resources such as the avoided costs of other expensive options as well the environmental and sustainable economic benefits it can provide.

5.5. OTEC Case Study: BAHAMAS



Source: <http://www.caribbeanislands.us/maps/bahamas-map.gif> accessed on Feb 4, 2012

Figure 22: Map of the Bahamas

The Bahamas Islands are part of an archipelago that stretches from 21° N to 27° 30' N latitude and 69° to 80° 30' W longitude. These islands consist of 19 populated islands [54] and hundreds of small cays and rocks, with total land area of 13,934 km². The entire archipelago covers 300,000 km² and stretches over 1,000 km. The population of the nation is limited but this

number is swelled by the roughly 5 million tourists who visit the country each year³². About two-thirds of the population resides in Nassau, the nation's capital, on the island of New Providence.

5.5.1. Climate and Geology

Climate ranges over the islands from subtropical temperate in the far north to semiarid in the far south. Rainfall patterns vary across the country. The northern part of the archipelago receives over 150 centimeters a year; the central area receives about 120 centimeters a year, while the southern area receives less than 100 centimeters a year. In the southern islands evaporation rates tend to be higher than precipitation [55]. The islands are all within the North Atlantic hurricane belt [56].

The islands in the Bahamas are about 150 million years old [57] formed after the breakup of the supercontinent, after North America had separated from Africa and Europe and created the space which, when filled with water, became present-day Atlantic Ocean [57]. The Bahamas Platform was formed in shallow water along the edge of the new ocean and is made up of a number of carbonate banks that are thick and covered with water generally less than 10 meters deep over most of their area and separated by deep water channels [58]. The islands are composed of carbonates precipitated from the ocean, and of sediments carried by wind and water and deposited over time. As the ocean levels rose and fell during and between glaciations, the surfaces were exposed and eroded by wind and water, and submerged and acted upon by the same elements. There are no true rivers or streams in the Bahamas. On the islands of Andros and San Salvador there are found a number of "bights" or "creeks" which are really estuaries and bays. Most of the surface is made of Pleistocene limestone on the interiors of the islands, while Holocene limestone covers the coastal regions. In the Pleistocene and Holocene limestone, freshwater aquifers have been formed by rain that seeped down through the porous surface and settled on the saltwater. Holocene sand aquifers form in strands and beach sands. Freshwater resources are finite and limited to very fragile freshwater 'lenses' in the shallow karstic limestone aquifers. The freshwater sits on top of the shallow saline water as a 'lens' which is less than 5 feet thick. Extraction from these aquifers is generally through shallow hand-dug wells, hand or electric pumps in uncased wells and through trenches and pits. Extraction is difficult from these aquifers, but there is potential for the retention of large amounts of freshwater in them. The

³² Public media articles quoting from the Bahamas Handbook, 2010

overall water availability in the Bahamas, according to the United Nations criteria, is sufficiently low to be considered 'scarce' and impacts the overall economic and social development of the country.

5.5.2. Water Supply

The several methods of fresh water supply and distribution in the islands are:

- Ground water unique to an island
- Ground water barged from one island to another
- Ground water piped from one island to another by underwater lines
- Private water wells
- Fresh ground water blended with brackish ground water
- Desalination (usually RO³³)
- Water trucking from one part of an island to another
- Bottled water

The primary source of drinking water is fresh ground water. Use of Reverse Osmosis is increasing and will most likely continue to increase, as fresh (ground) water availability continues to decline, and water demands grow. Rainwater catchment is rarely used, supplying less than 3% of the total water demand. Due to the nature of brackish ground water and the overall quality of water, the bottled water industry is highly developed in the islands with more than 27 companies operating across the islands. The amount of rainfall is also unevenly distributed across the islands and this has led to uneven distribution of freshwater sources. The islands of Andros, grand Bahamas and Abaco have the largest reserves of fresh water and supply water to some of the other islands through barges. The Bahamas W&SC³⁴ delivers water to 26 separate islands through more than 60 extraction and distribution systems. Daily delivery by the corporation exceeds 12 million gallons. However, there are also private players operating thousands of abstraction and mass distribution schemes.

³³ Reverse Osmosis (RO) is a membrane-technology filtration method that removes many types of large molecules and ions from solutions by applying pressure to the solution when it is on one side of a selective membrane

³⁴ Water & Sewage Corporation

While areas with accessible freshwater can be accessed with wells, trenches and pits, areas with inadequate freshwater resources opt for desalination and RO to produce potable water. RO is preferred over distillation because it is faster and cheaper than distillation.

5.5.3. Regulation

The Bahamas Government has developed a general legislation and regulatory framework for water management called the Water and Sewerage Corporation Act of 1976. In 2004, The prevailing pricing policy being implemented by the Government for cost-recovery is aligned towards extracting revenue from industry and household use and approximately 85% and 50% of water costs are recovered through pricing in New Providence and the Family Islands respectively. Water is supplied free of charge in economically depressed areas and the special needs of the poor are addressed through Government subsidies and pricing designed to support the poorer parts of the island.

5.5.4. Water Tariffs

The tariff for freshwater varies across the several Bahamas islands and is influenced by alternative sources of freshwater available in the corresponding island. It is the lowest in areas with natural sources of water where water can be easily extracted and the highest where the extraction costs are high. The tariffs are also subsidized heavily by the government.

The cost of sole sourcing freshwater through RO is six-eight times the cost of extracting freshwater from the ground. Though the cost of RO water is expected to come down, RO has an environmental impact in the form of brine waste which, when discharged improperly, can pollute aquifers and oceans. Another drawback of RO is that it is an energy-intensive process with energy costs taking up almost 25% of the total costs [55]. Even the blended cost of producing freshwater through RO and barging in water from other islands is four times that of obtaining it from a ground source.

5.5.5. Access to water

In the urban areas of the Bahamas, more than 50% is concentrated in New Providence, the concentration of economic activity in the islands. Of the total water supplied by the water authorities, 50-55% is barged from Andros, 22% from a company RO plant and the rest from

freshwater sources, usually private wells. The quality of water in these private wells, estimated at more than 30,000 in New Providence alone, is suspect as they are unregulated. The thriving bottled water industry uses Reverse Osmosis to desalinate followed by “ozonation”³⁵ for disinfection. New Providence’s own reserves are unsustainable and the amount of water barged in from Andros has to go up in the future to meet demand. Historically, during peak demand season, unsustainable pumping of water from the ground has led to significant compromises in the quality of water supplied to the population. Also the water sources are scattered all over the island is pushing up the costs of distributing freshwater.

In rural areas, water is still privately obtained by buckets from shallow hand-dug wells which contain less than one meter of water. Other methods include hand-pumping or electric-pumping systems which lift water to overhead storage, thereby supplying water for domestic purposes. Besides dug and drilled wells, public supply of ground water is obtained from trenches, pits and even rainwater catchments and is distributed through ground transport and under-water from one island to another. Water consumption in rural areas is reduced compared to places such as Andros and Abaco, because it is rationed.

5.5.6. Electricity in the Bahamas

The Bahamas Electricity Corporation is the main electricity supplier throughout the Commonwealth of The Bahamas. It is a state-owned electric utility operating over 29 generating plants in 25 Island locations. It currently provides service to approximately 96,000 customers and has a total installed capacity of 438MW in New Providence and the Family Islands. The electricity is generated fully from fossil fuels - 28 diesel engine stations and 1 gas turbine power station, and supplied to different islands through land or through submarine cables. The fuel for these power plants is imported and the corresponding import duties are passed on to the customers.

The electricity consumption has been steadily rising in the Bahamas and topped at close to 2 Billion kWh in 2011 with one of the highest per capita electricity consumption in the world³⁶ at

³⁵ Ozonation is a water treatment process that destroys bacteria and other microorganisms through an infusion of ozone, a gas produced by subjecting oxygen molecules to high electrical voltage.

³⁶ World bank, World development indicators

6264 kWh. The electricity rates for residential consumers are between 10.95 c/KWh and 14.95 c/KWh depending on consumption. For commercial units, it is a flat rate of 15 c/KWh. In addition, there is a built-in fuel surcharge in the electricity tariff to account for fluctuations in the cost of fuel used in the generation of electricity. This surcharge averaged 10 c/KWh in 2010 (based on latest data available on their website³⁷) adding up to a total electricity tariff of 25 c/kWh.

5.5.7. OTEC Potential in the Bahamas

The need for regulating and protecting the water resources in the Bahamas is essential. Tourism, which is the mainstay of the Bahamas' economy, is heavily dependent on good quality water. Agriculture in the islands also is heavily dependent on water and irrigation. Over-exploitation of this resource will have severe repercussions, including health issues from water-borne diseases and much greater water costs. The greatly increased cost of water will be due to treatment incurred as a result of ground water contamination, from the necessity to use Reverse Osmosis, and/or barging more water to meet demand. All these factors require that Bahamas plan very well for the protection of this valuable resource. OTEC is an attractive solution for the twin problems of sustainable electricity and water for the Bahamas islands. With OTEC it is possible to co-locate the supply of both electricity and freshwater within the same premises of a plantship or a shore-based land facility.

The Bahamas is already exploring viable options of renewable energy generation in the context of increasing oil prices, energy security and the global impact of climate change. The cost of importing oil for Bahamas is around \$ 800 million, which is almost 9% of their 2010 GDP³⁸, and this share might only go up in the coming years so much that in less than two decades, Bahamas might not be able to afford to import all the fuel that it requires. Also, Bahamas should understand the imperative of acting early with respect to climate change as it if will be one of the causalities of the consequences of climate change inaction, in the form of rising sea levels.

http://www.google.com/publicdata/explore?ds=d5bncppjof8f9_&met_y=eg_use_elec_kh_pc&idim=country:BHS&dl=en&hl=en&q=bahamas+electricity+consumption#ctype=m&strail=false&bcs=d&nselm=s&met_s=eg_use_elec_kh_pc&scale_s=lin&ind_s=false&idim=country:BHS&ifdim=country:region:LCR&hl=en&dl=en updated Jan 24, 2012

³⁷ http://bahamaselectricity.com/about/fuel_surcharge.cfm

³⁸ CIA Factbook, 2011

So an analysis using a previously completed study[29] will allow us to understand the economics of setting up an open-cycle OTEC plant for the Bahamas Island which can produce both electricity and freshwater. Deriving from Bahamas population statistics, the overall freshwater requirement for the islands in 2010 is (approx.) 21 trillion gallons per day catering to a population of 365,000 including a floating population of 5 million tourists who visited the islands in 2010.

Table 10: The Bahamas: population and water demand statistics

Island	Population (2000)	Population (2010)	Daily water demand in 2010 (MGD)
Abaco	13174	15,747	787,346
Acklins	423	506	25,281
Andros	7615	9,102	455,111
Bimini and the Berry Is.	2308	2,759	137,938
Cat Island	1548	1,850	92,516
Crooked Island	341	408	20,380
Eleuthera, Harbor Island & Spanish Wells	11269	13,470	673,493
Exuma & Cays	3575	4,273	213,660
Grand Bahamas	46954	56,124	2,806,211
Great Inagua	1046	1,250	62,514
Long Island	2945	3,520	176,008
Mayaguana	262	313	15,658
New Providence	212432	253,920	12,696,024
Ragged Island	69	82	4,124
San Salvador & Rum Cay	1028	1,229	61,439
Tourists³⁹	NA	13,699	2,739,726
All Bahamas	304989	364,554	20,967,430

Source: [55]

³⁹ 5 million tourists visited the islands in 2010, so that makes for a floating population of 13,699 tourists/day

As per Vega[29], a 50 MW open-cycle plantship (OC-OTEC) would require a 176 m long platform with a 90 meter beam resulting in a displacement of 247,400 tonnes (though the size of set-up would be a challenge for most shipyards) and can produce 414,415 MWh/year and 31.3 million Gallons per Day (MGD) at an annual cost (including both electricity and freshwater production) of \$ 97.2 million. For an open-cycle OTEC plant to be economically viable for a specific location, it has to be validated for the feasibility of delivering both the products of the plant, electricity and freshwater, at the prevailing market price.

Currently the tariffs for freshwater that is supplied from RO sources in the islands are heavily subsidized in most of the islands and are sold well below the purchase cost. The purchase costs in the island range from \$8 to \$20 /kGallon and is sold at an average tariff of 4.27 \$/kGallon [Table 11]. The islands spend almost \$ 1.94 million on purchasing water through RO sources (excluding costs that are involved in transporting and distributing the water) but they recover only a third of it through sales of water. The cost of subsidizing freshwater is almost \$1.2 million/year for the island water authorities.

Table 11: Capacities and costs of purchasing freshwater in The Bahamas

Location	capacity (kGallons/Day)	Purchase cost \$/kGallon	Purchase cost \$/year
Grand Cay, Abaco	10.50	20.83	79844
Black Point, Exuma	8.33	20.83	63368
Farmers Cay, Exuma	2.50	20.83	19010
Staniel Cay, Exuma	10.00	20.83	76042
Moores Island, Abaco	25.00	12.60	114975
North Bimini	83.33	9.91	301429
Inagua	41.67	14.50	220521
Deadmans Cay, Long Island	41.67	12.00	182500
Georgetown, Exuma	150.00	10.20	558450
Waterford, S. Eleuthera	62.50	14.30	326219
San Salvador	50.00	9.13	166531
Ragged Island	2.08	25.00	19010
TOTAL	487.58		1942358
AVERAGE		10.91	

Source: [55]

Table 12: Table to calculate the average price of water

Location	capacity (kGallons/Day)	Tariff \$/kGallon	Annual sales (\$/year)
Grand Cay, Abaco	10.50	5.00	19163
Black Point, Exuma	8.33	5.00	15208
Farmers Cay, Exuma	2.50	5.00	4563
Staniel Cay, Exuma	10.00	5.00	18250
Moores Island, Abaco	25.00	5.00	45625
North Bimini	83.33	2.88	87448
Inagua	41.67	2.88	43724
Deadmans Cay, Long Island	41.67	2.88	43724
Georgetown, Exuma	150.00	5.00	273750
Waterford, S. Eleuthera	62.50	5.00	114063
San Salvador	50.00	5.00	91250
Ragged Island	2.08	5.00	3802
TOTAL	487.58		760569
AVERAGE (\$/kGallon)			4.27

As per the design considerations of Vega[29], the costs and output of a 51.25 MW OC-OTEC plant which can produce electricity and water is:

Installed cost of OC-OTEC (\$ millions)	551 million
Annual Cost of electricity and water production (\$)	97.19 million
Annual Electricity (MWh/year)	414,415
Annual desalinated water (millionG/day)	31,287
Cost of producing electricity ⁴⁰	227\$/MWh

⁴⁰ Assuming a capacity factor of 95% for the plant

In this design, the cost of producing electricity is 227\$/MWh which is comparable with our estimates earlier in his report (though this plant was uniquely designed for the co-production of freshwater along with electricity)

So, for an open-cycle OTEC plant to break-even, the price of co-generated product, assuming the other product is sold at prevailing market price, is:

Case 1:

Calculating the minimum price of freshwater, assuming electricity is sold at the minimum market price of 21 c/kWh (including the 10 c/kWh fuel surcharge)

Annual revenue from electricity production = \$210/MWh X 414,415 MWh
= \$87.03 million

Therefore, minimum revenue to be anticipated from freshwater sales to break-even costs
= \$ (97.19 - 87.03) million
= \$10.17 million

Therefore, price of water should be at least **\$ 0.89/kGallon**

Case 2:

Calculating the minimum price of electricity, assuming freshwater is sold at the minimum market price of 4.27 \$/kGallon [Table 12]

Annual revenue from freshwater production = \$4270/MG X 31.29 MG/day X 365
= \$48.76 million

Therefore, minimum revenue to be anticipated from electricity to break-even costs
= \$ (97.19 - 48.76)
= \$ 48.43 million

There, price of electricity should be at least **0.12\$/kWh or 12 cents/kWh**

The above results show that fresh water and electricity can be co-generated in an open-cycle OTEC facility and can be sold at prices which are significantly lower than current market prices. The results of this analysis show that freshwater produced through OTEC can be sold at 0.89\$/kGallon which is less than one-fourth the current purchase of 4.27\$/kGallon. This is a big incentive for the country to adopt this integrated approach to solve the freshwater problem and an anticipated growth in electricity demand. This technology will help the island water

authorities to mitigate the burden of subsidizing purchase of RO filtered water from private sources. Of course, the above cost calculations make assumptions about the distribution of OTEC water to different islands and different parts of some of the larger islands. While some new infrastructure can be built in the long-term to support this concept, it can make use of the existing water distribution infrastructure as well. This analysis also does not take in account other benefits such as avoided cost of scaling up the water import infrastructure across various islands.

The above cost calculations show that OTEC can be a potential technology to be located in islands such as the Bahamas with a combined requirement for water and freshwater production. Co-location of these two essential resources though OTEC will also help showcase the technology for regions with similar challenges in the supply of these two essential utilities.

6. OTHER BY-PRODUCTS OF OTEC

Besides freshwater, there are several other non-fuel by-products that can be realized by OTEC along with electricity generation. This includes using the cold water from the deep ocean for sea water air-conditioning, marine culture, and chilled soil agriculture. OTEC also acts as an energy carrier by the production of hydrogen, methanol, ammonia and synthetic liquid hydrocarbon (Jet fuel)

6.1. Sea Water Air Conditioning (SWAC)

The cold water that is brought up through the cold water pipe can be used to create cold storage space, as well as for air-conditioning. There are several working applications of chilling using the cold deep ocean water. The laboratory at the Natural Energy Laboratory of Hawaii is air-conditioned by passing the cold sea water through a heat exchanger. Similar small-scale applications would be appropriate among tropical islands. Companies in the seafood export business can use deep ocean water in plantships as an economical substitute for refrigeration. Economic studies have been performed for even metropolitan and resort applications. Air-conditioning of new developments with cold sea water, such as resort complexes, can be economically attractive even if utility-grid electricity is available.

For air-conditioning applications, the cold seawater delivered to an OTEC plant can be used in chilled-water coils. It is estimated that a pipe 0.3 m in diameter can deliver 0.08 cubic meters of water per second. If 6°C water is received through such a pipe, it could provide more than enough air-conditioning for a large building. If this system operates 8000 hours per year and local electricity sells for 5¢-10¢ per kilowatt-hour, it would save \$200,000-\$400,000 in energy bills annually⁴¹

6.2. Chilled-soil agriculture

Takahashi and Trenaka [10] in 1992 discussed an idea initially proposed by Siegel of the University of Hawaii which involves the use of cold seawater for agriculture. This proposal involved burying an array of cold water pipes in the ground to create cool-weather growing conditions not found in tropical environments. In addition to cooling the soil, the system

⁴¹ Based on a study by Department of Energy, 1989

produces drip irrigation created by the atmospheric condensation on the cold water pipes. M. Vitousek of the University of Hawaii carried out actual demonstrations and determined that strawberries and other spring crops and flowers could be grown throughout the year in the tropics using this method. Following several years of research, commercial developers have constructed a one-acre test plot.

6.3. Marine culture

Marine food production is a potential by-product of OTEC power plants. With the alarming loss of topsoil throughout the world our agricultural production will not be able to keep up with increase in demand. Hence, ocean may well become our most important source of food, even more important than the power generated. The ocean is the one of the greatest potential source of food and OTEC might just be the answer for producing more food.

Deep ocean water contains a much higher percentage of nitrates and phosphates than contained in the upper layers. Studies show that when cold waters are brought to the surface by upwelling, the fish-production is significantly increased. The greatest fish-producing area in the world is off the west coast of South America where the Humboldt Current brings deep water to the surface, and supplies the fertilizer to produce millions of tons of fish annually. Since an ocean thermal power plant necessarily pumps up cold water to be utilized in the plant, and since the process warms this water in the plant, it is natural to think that this nutrient rich water can be discharged into the near-surface zone where sunlight can promote growth of micro-organisms and the entire chain of marine life developed from this food supply. This valuable by-product can be cultured in open systems near the surface or in closed systems with pens and fences.

6.4. OTEC as an energy carrier

An OTEC facility can improve its economic viability by producing energy-intensive products as it will not require production or transmission of electricity on land. There are a few products that can be produced directly from electrolysis of sodium chloride water solution. Electrolysis of a sodium chloride solution produces three products: Caustic soda, Chlorine and Hydrogen. All are in high-demand throughout the world. Other products that have been studied in the past as convenient by-products of the OTEC process are oxygen, nitrogen, and carbon dioxide. The percentage of oxygen dissolved in sea-water is 34% of the gases whereas it is only 23% in

normal air. This means that the gases removed during the water desalination process contain a higher percentage of oxygen than normal air, and thereby become a convenient source for a gas separation plant which can produce carbon dioxide, oxygen and nitrogen. Since power is conveniently available for this process and cold water is also available to make the oxygen separation process more efficient, it seems obvious that an OTEC will be an excellent source for these valuable gases.

6.4.1. Hydrogen

Hydrogen and oxygen can be produced from pure water by electrolysis by one of the several industrial processes that have been developed for this purpose. An ocean thermal plant can be an excellent source of hydrogen, which can be used as fuel or can be used in chemical combination for other products.

A 100 MW OTEC plant would be capable of supplying enough electricity to generate 563,000 m³/day of hydrogen through commercial off-the-shelf conventional electrolysis equipment. The hydrogen produced by this conventional process would then be utilized in a gas to liquids catalytic process capable of producing approximately 41,000 gallons of liquid hydrocarbon per day as previously reported [59]

6.4.2. Methanol

Once hydrogen and carbon dioxide have been produced from sea-water, the next step is to combine them in a catalytic process which produces methanol. Methanol is a valuable liquid fuel which can be used directly in automobile engines, or can be combined with gasoline to produce the fuel commonly known as gasohol. Further processes are also available for converting hydrogen and methanol into hydrocarbons. Therefore, hydrocarbon fuels are also a potential by-product from ocean thermal plants.

6.4.3. Ammonia

One of the products that can be produced using hydrogen is ammonia. There is a worldwide demand for ammonia for fertilizer and other purposes, especially in several tropical nations of the world. Ammonia is produced by the direct combination of nitrogen and hydrogen, and many studies show that ocean thermal plants are a most logical source for producing ammonia. The

Johns Hopkins University Applied Physics Laboratory has made extensive studies of the economics and practicality of producing ammonia in an ocean thermal plant [6, 49]. Of all the energy intensive by-products that OTEC is capable of producing, ammonia was considered an important candidate for production from OTEC plants due to its high volume of end use in fertilizers and other chemicals [20]. Ammonia production through OTEC may provide an important alternative to the production of these products from natural gas. Here, OTEC competes with other non-renewable resources such as petroleum and coal. Though production of ammonia from natural gas has the lowest estimated cost in \$/short tons, OTEC scored favorably with respect to relative environmental impact. The optimum commercial size for OTEC/ammonia plant-ships is expected to be in the 1000--1700 STPD⁴² range requiring an approximately 300-500 MW plant [60]. Economics of scale are possible due to centrifugal compressors in the ammonia synthesis plant beyond the threshold production of 600 STPD. Also, traditional methods of ammonia production are highly carbon negative so once carbon credits are accounted for, the economics of OTEC ammonia production can be significantly improved.

6.4.4. Jet Fuel

It is possible to use the Carbon Dioxide (CO₂) generated from the OTEC process as a carbon source for the production of synthetic liquid hydrocarbon fuel (Jet Fuel). The CO₂ content liberated as gas from ocean water by the OTEC process is actually only 2-3% of the total CO₂ in ocean water. The rest of the CO₂ is present as dissolved bicarbonate. The concentration of dissolved CO₂ in the ocean is about 140 times greater than that found in air[61]. So if there is a process designed to harvest this CO₂ coupled with the OTEC process, the overall recovery efficiency can greatly increase jet fuel production.

A large 100 MW OTEC platform can remove the heat energy content of 1.12 billion gallons of seawater per day [3][60]. This translates into a potential of 20-30 tons of carbon from CO₂ that is available from the OTEC process. There can be additional harvesting of CO₂ from the remaining 97% bound as bicarbonate. This process would use the cold deep ocean water and for each gallon of water pumped, the heat energy content and the total carbon content will be removed at the same time. This can result in the production of 500 tons of additional CO₂ per day for Jet fuel production [59].

⁴² Short Tons Per Day

7. ENVIRONMENTAL IMPACT OF OTEC

Environmental impacts of ocean thermal energy conversion projects are specific to the site, configuration, architecture used and the technologies deployed. Structures associated with OTEC will have similar environmental impacts as other structures placed offshore, by virtue of their physical presence in the water. Adverse impacts to the environment can be avoided or mitigated by careful site selection and project design (including elements such as structural design, materials used, construction techniques and operational requirements). Though OTEC appears to be environmentally benign as there is neither routine discharge of chemical pollutants nor combustion, it broadly impacts coastal processes, marine biology, air and water quality, visual environment and geology similar to other marine renewable technologies. There are also some environmental impacts unique to the configuration of the OTEC facility. These must be carefully studied before a large-scale facility is deployed. Though these effects might not be currently significant to influence investment decisions in this technology, it is useful to study these effects in detail to ensure that it does not pose a potential environmental roadblock. Some of the specific environmental impact areas of OTEC are:

7.1. Entrainment and impingement of organisms

Impingement and entrainment of small organisms occur at both the warm-water and cold-water inflow points in an OTEC system. Organisms impinged by an OTEC plant are caught on the screens protecting the intakes but usually impingement is fatal to organisms. Smaller organisms that are entrained through the screen may be exposed to biocides, physical abuse (acceleration, impaction, shear forces, and abrasion), and temperature and pressure shock [62]. Entrained organisms may also be exposed to working fluid and trace constituents⁴³. Intakes should be designed to limit the inlet flow velocity to reduce impingement of organisms. The organisms that are impacted by the warm water inlet pipe include micronekton⁴⁴ and plankton communities, the latter include holoplankton⁴⁵ (permanent members, such as phytoplankton⁴⁶ and zooplankton⁴⁷)

⁴³ Trace metals and oil or grease

⁴⁴ Micronekton are relatively small but actively swimming organisms ranging in size between plankton (< 2 cm), which drift with the currents, and larger nekton (> 10 cm), which have the ability to swim freely without being overly affected by currents

⁴⁵ Plankton that remains free-swimming through all stages of its life cycle

⁴⁶ Minute, free-floating aquatic plants

and meroplankton (temporary members, such as eggs and larvae of fish or benthos). At the cold water intake point, the organisms that are impacted are largely small vertebrates and invertebrate micronekton with relatively sparse macronekton.

7.2.Upwelling of nutrient-rich deep ocean water

OTEC helps with artificial upwelling of the ocean water - a process which imitates natural upwelling responsible for the most productive marine environments on the planet - to fertilize surface ocean waters which are deficient in nutrients. This process will stimulate the food chain by increasing the growth of plankton. The increased plankton can be used to increase the stock of fish in these nutrient-rich waters. This process helps to relocate nutrient-rich water from the deep of the ocean to the surface and uses energy from the sun to create fish biomass for the world. There are several positive side effects from this type of marine farming. For example, the increased biomass of phytoplankton as a result of marine farming will also help remove carbon CO₂ from the atmosphere and reduce global warming, notwithstanding the fact that it is a perturbation to the natural system with potential of unintended consequences.

7.3.Lowering surface temperature

There have been discussions [63] on whether the cold water discharged from an OTEC plant would alter the temperature of surface ocean water. But the alterations in temperature seem to be minimal over large ocean areas. Also, the warm water discharge could potentially lower the ocean surface temperature near a plant and a large collection of plants could potentially reduce surface temperatures over a larger region. These effects need to be studied before OTEC is implemented on a large scale, but it should not affect the decision to site a few small plants. On the other hand, OTEC is considered as a technology which can have a positive impact on hurricanes' formation. Hurricanes form in warmer waters and dissipate when incurring a temperature drop of surface ocean water [64]. Hence OTEC discharge can be the mechanism to lower the temperature of the ocean surface and minimizing the severity of severe storms in the hurricane-prone island areas of the Atlantic, Pacific, and Indian oceans.

⁴⁷ Plankton that consists of animals including the corals, rotifers, sea anemones and jellyfish

7.4. Other impacts

There are also generic environment impacts on marine renewable technologies discussed in papers [62][65][66] which are applicable for OTEC power plants:

7.4.1. Structure

Structures can attract fish species and provide substrate for some invertebrates. This can lead to possible physical and biological effects such as changes in food availability, species composition, predator/prey interactions and competition between species. Direct effects due to underwater and surface structures include direct impact by altering animals' movement patterns, providing haul-out and roosting sites, and providing foraging habitat. The OTEC platforms can serve as resting platforms for marine birds which can result in changes to their flying patterns and local distribution. Structures might entangle marine debris such as fishing nets, and this can in turn attract and entangle animals. Also, species of marine organisms, fish, and diving marine birds can have direct collision with underwater and near-surface moving parts of OTEC structures. This can lead to serious threat of marine habitat in the specific location. In the long-term this can have a significant impact of the distribution of species in the specific location.

7.4.2. Construction and deployment noise and vibration

Noise and vibration effects related to OTEC activities are dependent on the characteristics of the noise, weather, sea conditions, and ambient noise due to natural processes and anthropogenic activities. Drilling into the sea-bed for installation of foundations of the platform structure or directional drilling and trenching for the transmission cable and/or operation of instruments related to everyday maintenance of the OTEC plant produce noise and vibration. These in-water and surface vibrations could disturb marine birds, fish and other marine organism which use sound for communication, prey or predator location, and/or echolocation.

7.4.3. Seabed disturbance

The seabed will be temporarily disturbed from laying or trenching the power transmission cable, installing foundations for OTEC structures and from scouring moorings leading to localized and unnatural water circulation. This could result in changes in sediment chemistry mobilizing

pollutants and disrupting sediment oxidation-reduction conditions. Benthic⁴⁸ spawning activities of fish and invertebrates, including coral reefs, are also disrupted due to the high levels of turbidity. Seabed disturbance impacts marine birds by temporarily displacing local food availability.

7.4.4. Water circulation changes

OTEC structures can modify waves or tidal patterns which can alter sediment transport and deposit processes disturbing sediment size, volume, and chemistry. This can further alter sediment transport and beach processes and affect bays, inlets, and estuaries that are sensitive to sand dynamics. These changes also have the potential to alter habitat and/or affect availability and distribution of food resources for a wide variety of marine organisms.

7.4.5. Electromagnetic field

Power transmission cables that transmit alternating and direct current from offshore OTEC structures to the mainland could interact with species which are sensitive to electric and magnetic fields. While cable insulation can be adequately effective on the electric fields associated with AC transmission, magnetic fields might not be completely insulated and this leakage could result in induced electric fields. The electromagnetic field emissions are within the range of those utilized by species sensitive to electric and magnetic fields such as elasmobranches, sturgeons, salmonids and marine mammals

7.4.6. Light disturbances

Marine birds can be attracted to lights on OTEC structures and collide with these lighted structures or exhaust themselves by continual flying around these lights. Most probably, navigation lights associated with boats used during construction, maintenance and decommissioning activities will be installed on OTEC components. Navigational lights are also assumed to be present throughout the life of the project. While former are usually significantly brighter but temporary, navigational lights will be less intense though available through the duration of the project. The OTEC project design should include a thorough study on the intensity, color and pattern of lights which could have an impact on marine birds, some fish species and pelagic invertebrates.

⁴⁸ Relating to the bottom of a water body

7.4.7. Chemical releases

The working fluid and other chemicals (c.g., hydraulic fluids, anti-fouling paint, fuel) used during construction, operation, maintenance, and decommissioning of an OTEC plant could be accidentally released into the marine environment. Changes in the environment from such releases would depend on the type, volume, and rate of chemical release. Chemicals could be ingested and become toxic to a host of marine organisms. For example, marine birds that get oil on their feathers lose feather waterproofing, causing hypothermia and other physiological effects associated with ingestion of toxic chemicals during preening. These effects will likely be temporary, as chemical releases would eventually dissipate; the duration of effects would depend on the size of the release.

7.5. Ecological Risk Assessment – Comparison of OTEC with other ocean energy technologies

In a recent study on ecosystem-based approach to environmental assessment [62], the Ecological Risk Assessment (EcoRA) framework was used to identify and prioritize risks from three different ocean energy technologies – wave, tidal and OTEC. This study used the EcoRA framework based on the current knowledge of environmental impact of all these ocean technologies due to specific stressors⁴⁹ in the system as well as the interaction of other these stressors with other paralleling occurring stressors. The risk ranking table shows the impact of technology on various endpoints in the ocean. OTEC's two biggest impact areas are on fishes and plankton. This seems to be the result of the major risk discussed earlier in this chapter, with regard to entrainment and impingement of fish and plankton at the intake points of the pipes used in OTEC. Plankton, Eggs/Larva and Corals are endpoints that are highly impacted by OTEC compared to the other two ocean energy technologies. Overall, all the ocean technologies, including OTEC seem to fairly impact the existing habitat of the location they are deployed in. Based on this meta-analysis, it might be useful to prioritize and pursue in-depth future research in specific high impact areas for OTEC and delve into the nature and scale of the impact, so that these don't become show-stoppers in viability discussions of this technology.

⁴⁹ Stressor is a chemical or biological agent, environmental condition, an external stimulus or an event that causes stress to an organism. An event that triggers the stress response may include conditions such as elevated sound levels, over-illumination, overcrowding, etc

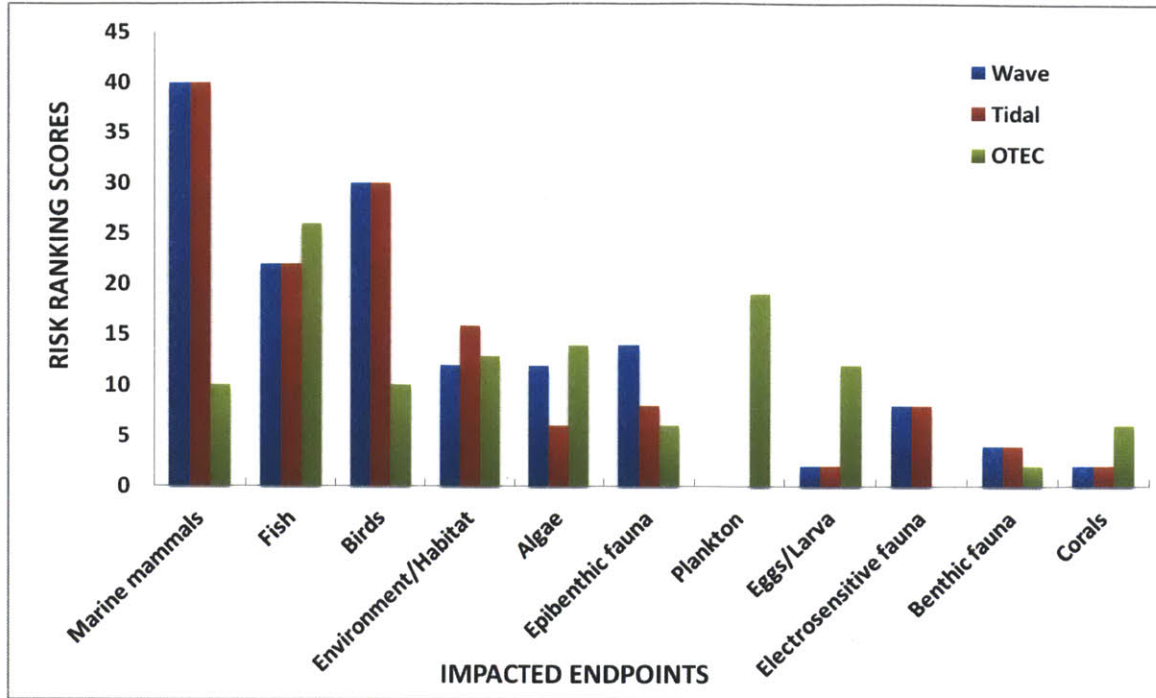

Source: [62]

Figure 23: Comparison of risk ranking scores of ocean renewable energy technologies

8. CONCLUSION

In this report, we found that for OTEC plants producing a single product, either electricity or an energy-intensive product such as ammonia, the capital costs per installed kW are projected to decrease by 22% when the capacity of the plants is doubled. This result is based on a meta-analysis of cost projections in the published literature. Also, for the 400 MW grid-connected designs, the overall levelized LCOE is projected to be lower than that of renewable technologies such as offshore wind, solar PV, solar thermal. It is projected to be within competitiveness with that of an advanced coal plant with CCS. However these cost projections are uncertain. Due to the inherent risks of a new technology, the adoption of OTEC may be limited if it is viable only at a large-scale of output. It is important to identify options to control upfront investment costs in OTEC plants of smaller scale. This can be done by either reducing the technology costs or by innovatively financing OTEC projects. If the upfront investment costs can be managed, the relatively high capacity factor and low O&M costs of the technology can improve the potential of OTEC as a base load generation technology.

Of all the components contributing to the high capital costs, the water ducting systems seem to be the most challenging, with maximum uncertainty in costs. This is consistent with historical studies which show that the design and deployment of large diameter cold water pipes have been a major impediment to commercialization of the technology. Technologies borrowed from other industries solve the problem for small-scale designs but larger pipes for OTEC require much more effort in research and development. Smaller, modular pipes seem to be the alternative discussed by some experts but the concept lacks sufficient research and demonstration support.

The technology can work for small island communities in the global OTEC resource zones, co-generating electricity and freshwater. The Bahamas case study in our report shows that the viability of this technology improves with co-generation of both electricity and water, with the estimated price of OTEC water beating the current purchase cost of 'Reverse Osmosis' water by more than 75%. It is almost certain that the simultaneous production of other by-products of the deep ocean water of the OTEC system such as seawater air-conditioning, chilled soil agriculture and marine aquaculture can further improve the viability of the system. These products not only improve the economic feasibility of the technology but can also solve other issues such as electricity demand management and improved agricultural yield. This shows that the technology

should be viewed holistically, as an integrated sustainable solution for small communities that can solve several problems, besides mere electricity generation.

8.1. Attractiveness as a base load generator

Our analysis shows that for coastal regions in the OTEC-friendly zone, OTEC may be one of the potential renewable energy sources to provide base-load power to utilities in the near future. The high capacity factor of OTEC ensures availability throughout the year, an important characteristic of energy technologies serving base load. New investments in base load generation should consider the technology if the region can afford the upfront investment. The significant capital costs can be partially offset by combining electricity production with any of the by-products discussed in this report, though detailed studies have to be carried to understand the overall financial viability of such co-generation projects. The land-based/moored configuration of the technology can be viable for inland areas, provided a strong grid-network connects the coast with the interior regions.

8.2. Importance of scale

This study has shown that investments in OTEC become more favorable with scale, as costs are projected to decrease by more than one-fifth with every doubling of plant output. But the capital intensive nature of OTEC projects will be a deterrent to immediate large-scale investment, especially by private investors. Energy technologies such as wind and solar might be seen as less risky renewable energy investment options, given their proven costs and performance. Also, as these technologies are currently ahead of OTEC in market maturity, their levelized cost of energy might continue to decrease significantly in the coming years. These other available options for renewable electricity generation may impede investments in OTEC.

8.3. Key to the energy-water nexus

OTEC has the potential to become a key technology to help solve global water issues. Countries should explore integrated energy-water production designs and conduct economic assessments of co-locating OTEC with other products. The Bahamas case study in this report clearly supports the technology as a sustainable solution for island nations with electricity and freshwater supply constraints. As island nations become more populated and the price of oil increases, both fossil

fuel plants and importing water from energy-intensive RO sources might turn expensive. The plantship/moored OTEC configuration also saves precious real estate in small island nations. But such integrated solutions might require several government departments to work together and study the benefit of OTEC as a holistic solution for community-level sustainability. Detailed multi-disciplinary studies should be carried out to validate the sustainability of this technology, including the localized environmental impact of this technology. Even if there is no current market for integrated solutions, governments can make design provisions in the electricity-only configuration to augment with by-products once the viability of such projects are firmly established.

8.4. Current Challenges

The engineering feasibility of open-cycle and closed-cycle OTEC plants has been assessed by many independent investigators in recent years. Engineering design and development for OTEC is supposed to be a relatively easy task as documented in several reports. Individual component demonstrations have been conducted in the past, with moderate success. The missing link is the conversion of these tests into operational large-scale demonstration projects. Though there have been several short-term prototypes of the technology, none have succeeded in attracting large investments in working plants. Commercialization of this technology will require focused effort from all interested stakeholders in the system – the scientists, engineers, government authorities, and the investor community. Most energy consumers and investors have traditionally indicated a bias towards land-based plants and an resistance to water-based power plants[67]. Their degree of participation will depend upon the projected cost of power, the capital investment required and the degree of risk involved.

Commercialization constraints currently seem to be both technical and financial. On the technical side, there has been no continuous planned funding for R&D and demonstration of the technology. There has been relatively little information dissemination about this technology which might allow public input to influence policy decisions. There also seems to be a delay in finalizing specifications, regulations, and classification codes to accelerate engineering progress. For example, an exclusive OTEC environmental impact analysis is important and may help accelerate the licensing and permit procedures for OTEC plants.

On the financial side, there is currently no plan for federal cost-sharing of demonstration plants. Currently OTEC is unable to compete economically with conventional forms of power generation or even other renewables such as wind and solar. The technology does not have special tax credits or instruments such as loan guarantees which can help mitigate investor reluctance to go for this capital-intensive technology.

8.5. Recommendation

For OTEC, which has been around for more than a 100 years, there are several obstacles that have to be crossed before it moves from an experimental stage to commercially deployable in large-scale sites. The first challenge was a technological one, of scaling various components of the system, but seems to have been conquered to a large extent thanks to advances in other industries and continuous work by experts and industry pioneers in the field. What the technology currently requires is a fully functional large-scale OTEC plant to allow for experimentation with materials, processes and make advances unique to this technology.

The technology should be supported by better regulation or other legal standards which are mandatory to promote investments in the sector. Plantship/moored OTEC facilities can be subject to maritime law as well as the codes, standards and other programs already applicable to maritime shipping. This will help with siting and security concerns of such plants. There should be an international agreement and design of an OTEC permit for plantships to operate in international waters outside the 200-mile economic zone. This might require a trans-national MOU⁵⁰ between governments to jointly utilize ocean thermal sites as resource sites which benefit several countries simultaneously and collectively help address global energy and water issues. Such regulation and licensing initiatives have to be jointly framed by countries which have pioneered this technology, especially USA, Japan and some of the small island nations discussed in this report.

Financing this concept will require new models that reduce the risk of the upfront investment costs. Innovative funding models should be identified and borrowed from industries which have overcome similar commercialization challenges. The inherent design flexibility allows for innovatively enhancing this technology's investment opportunity through modularization of

⁵⁰ Memorandum of Understanding

capital investment. This approach will require breaking down the capital costs of an OTEC plant to allow the main stakeholder to own the core facility and lease out the power modules to other stakeholders, thereby entering into a co-owner model for an OTEC plant. This will help reduce the capital cost burden on a single entity as well spread the risk across multiple stakeholders. This will be especially beneficial in situations where the OTEC plant is producing products other than just electricity. In the initial demonstration plants, modularizing the project can even lead to OTEC plant designs which can produce combinations of more than one by-product, such as fresh water and seawater air-conditioning, marine aquaculture and seawater air-conditioning, etc. The modular nature of the technology and locational flexibility of OTEC can allow its facilities to be produced, owned and operated by established organizations and facilities. OTEC may garner support and services from shipyards, shipping companies and maritime labor, as they have supported energy producers in the oil and chemical industry. This can also act as a job-creation mechanism in these mature industries.

Governments also have a huge role to play in promoting investment in OTEC plants. Initial large-scale plants might have to be funded through public-private shared funding. The initial plants can also be viewed as a test bed to benchmark operating parameters of the technology. Government can also help prioritize detailed research on the economics of by-products and the environmental impact of the technology.

8.6.Discussion

OTEC has the potential to be many things to many regions, with no fuel costs, negligible emissions and minimal environmental impact. There are several possible combinations of OTEC products or by-products which makes this technology attractive for sustainability planning of small coastal communities, especially those of island nations. OTEC can be a source of power and freshwater, satisfy cooling requirements, and even help solve food issues by changing the agricultural landscape of a region (through chilled soil agriculture or improved marine aquaculture). But all of these products may not be needed in all of the OTEC resource regions. One attractive approach would be to customize various combinations of OTEC products for particular markets.

The final hurdle to cross is a social one. As large-scale deployment of this technology gets underway, there will be apprehension regarding the cross-border nature of this technology and the environmental impact of the technology. The former requires a political solution with several national agencies working together to collectively promote this technology as part of a sustainable future. The latter will require awareness of this technology to cross over from an expert level to a mass level, as achieved by other renewables such as solar and wind. This will require the experts in this area to create awareness and education. In this way collective innovation may tackle the unique challenges of this technology by the “network effect”⁵¹.

8.7.Future work

The work covered in this report shows how OTEC can be viewed as an integrated solution for small island communities, solving not only energy issues but also water and food issues. This offers ample opportunities for further research on an integrated economic assessment model of OTEC architectures to tackle these issues. In this report, we estimate the influence of scale on the levelized cost of energy through a meta-analysis of existing cost projections. Further investigation of how the design of each of the major component might change with the scale of the plant is warranted. Also important is further research on how these components will have to be modified for plants producing more than one product.

There is also gap in OTEC literature around the customization requirements for parts that have to be borrowed from other industries such as offshore oil drilling. Another area of research can be innovative financing models for large-scale deployment of OTEC. Finally there is work to be done around requirements of national and international regulation to deploy grazing OTEC plantships in international waters. Such work can explore options for how several nations can collectively fund this technology and share the immense energy potential of the oceans.

⁵¹ In economics and business, a network effect is the effect that one user of a good or service has on the value of that product to other people.

9. SOURCES

- [1] H. C. Soerensen and A. Weinstein, "Ocean Energy : Position paper for IPCC," in *IPCC Scoping Conference on Renewable Energy*, 2008, p. 8.
- [2] Coastal Response Research Center, "Technical Readiness of Ocean Thermal Energy Conversion (OTEC)," Durham, NH, 2010.
- [3] W. H. Avery and C. Wu, *Renewable Energy from the Ocean: A Guide to OTEC*. New York: Oxford University Press, Inc., 1994, p. 446.
- [4] D. F. Othmer and O. A. Roels, "Power, fresh water, and food from cold, deep sea water," *Science*, vol. 182, no. 4108, p. 121, 1973.
- [5] 2011J. T. R. on D. W., "Drinking Water: Equity, Safety and Sustainability," United States Of America, 2011.
- [6] N. Gilbert, "Balancing water supply and wildlife," *Nature*, Sep. 2010.
- [7] A. LAVI, "Ocean thermal energy conversion: a general introduction," *Energy*, vol. 5, no. 6, pp. 469-480, Jun. 1980.
- [8] J. Hilbertanderson, "Ocean thermal power—The coming energy revolution," *Solar & Wind Technology*, vol. 2, no. 1, pp. 25-40, 1985.
- [9] H. Uehara, "the Present Status and Future of Ocean Thermal Energy Conversion*," *International Journal of Sustainable Energy*, vol. 16, no. 4, pp. 217-231, 1995.
- [10] P. Takahashi and A. Trenaka, "Ocean thermal energy conversion: its promise as a total resource system," *Energy*, vol. 17, no. 7, pp. 657-668, 1992.
- [11] H. Kamogawa, "OTEC research in Japan," *Energy*, vol. 5, no. 6, pp. 481-492, Jun. 1980.
- [12] L. a. Vega, "Ocean Thermal Energy Conversion Primer," *Marine Technology Society Journal*, vol. 36, no. 4, pp. 25-35, Dec. 2002.
- [13] G. C. Nihous, "An Order-of-Magnitude Estimate of Ocean Thermal Energy Conversion Resources," *Journal of Energy Resources Technology*, vol. 127, no. 4, p. 328, 2005.
- [14] G. C. Nihous, "A Preliminary Assessment of Ocean Thermal Energy Conversion Resources," *Journal of Energy Resources Technology*, vol. 129, no. 1, p. 10, 2007.
- [15] G. T. Heydt, "An assessment of ocean thermal energy conversion as an advanced electric generation methodology," *Proceedings of the IEEE*, vol. 81, no. 3, pp. 409-418, Mar. 1993.
- [16] H. J. White, "Mini-OTEC," in *International Journal of Ambient Energy*, pp. 75-88.

- [17] A. Thomas and D. L. Hillis, "First production of potable water by OTEC and its potential application," *Solar Energy*, pp. 1045-1048, 1988.
- [18] R. Cohen, "An Overview of Ocean Thermal Energy Technology, Potential Market Applications, and Technical Challenges," *Proceedings of Offshore Technology Conference*, May 2009.
- [19] L. A. Vega, "Economics of Ocean Thermal Energy Conversion (OTEC)," in *Ocean Energy Recovery: the State of the Art*, no. 8, American Society of Civil Engineers (ASCE), 1992, pp. 152-181.
- [20] G. L. Dugger and E. J. Francis, "Design of an Ocean Thermal Energy Plantship to produce Ammonia via Hydrogen," *International Journal of Hydrogen Energy*, vol. 2, pp. 231-249, 1977.
- [21] R. Fuller, "Ocean thermal energy conversion," *Ocean Management*, vol. 4, no. 2-4, pp. 241-258, Dec. 1978.
- [22] L. A. Vega and D. Michaelis, "OTC 20957 First Generation 50 MW OTEC Plantship for the Production of Electricity and Desalinated Water," *Renewable Energy*, no. Cc, 2010.
- [23] N. Srinivasan, "A New Improved Ocean Thermal Energy Conversion System with Suitable Floating Vessel Design," in *Engineering*, 2009, pp. 1-11.
- [24] N. Srinivasan and M. Sridhar, "Study on the Cost Effective Ocean Thermal Energy Conversion Power Plant," *Offshore Technology*, pp. 1-13, 2010.
- [25] C. M. Wang, a. a. Yee, H. Krock, and Z. Y. Tay, "Research and developments on ocean thermal energy conversion," *The IES Journal Part A: Civil & Structural Engineering*, vol. 4, no. 1, pp. 41-52, Feb. 2011.
- [26] C. Chaplin, R. U, C. J. M. D. Vecchi, and P. S.A., "Appraisal of lightweight moorings for deep water," in *Offshore Technology Conference*, 1992, pp. 189-198.
- [27] O. T. Conference, "OTC 21016 Economics of Ocean Thermal Energy Conversion (OTEC): An Update," *Renewable Energy*, pp. 1-18, 2010.
- [28] L. Martel, "OTEC Life-Cycle Cost Assessment." Lockheed Martin Corporation, Unpublished⁵²

⁵² This material is based upon work supported by the Department of Energy's Office of Energy Efficiency and Renewable Energy (EERE) Wind and Hydropower Technologies Program (WHTP) under award number DE-EE-0002663. This report was prepared as an account of work sponsored by an agency of the United States government. Neither the United States government nor any agency thereof, nor any of their employees, makes any warranty, express or implied, or assumes any legal liability or responsibility for the accuracy, completeness, or usefulness of any information, apparatus, product, or process disclosed, or represents that its use would not infringe privately owned rights. Reference herein to any specific commercial product, process, or service by trade name, trademark, manufacturer, or otherwise does not necessarily constitute or imply its endorsement, recommendation, or favoring by the United States government or any agency thereof. The views and opinions of authors expressed herein do not necessarily state or reflect those of the United States government or any agency thereof.

- [29] L. A. Vega and D. Michaelis, "OTC 20957 First Generation 50 MW OTEC Plantship for the Production of Electricity and Desalinated Water," *Renewable Energy*, no. Cc, 2010.
- [30] U. E. I. Administration, *Annual Energy Outlook 2009, with Projections to 2030*, vol. 383, no. April. Energy Information Administration, 2009.
- [31] P. Smith, "Basis of Estimate, Capital Expense, DoE OTEC Life Cycle Cost, Revision A," The Glosten Associates, 2011⁵²
- [32] L. Martel, L. Pavlosky, and M. Thomas, "OTEC operations and maintenance cost analysis & model overview.," Lockheed Martin Corporation, Unpublished**Error! Bookmark not defined.**
- [33] T. Spencer and P. Altman, "Climate Change, Water, and Risk: Current Water Demands Are Not Sustainable,," 2010.
- [34] I. C. Karagiannis and P. G. Soldatos, "Water desalination cost literature: review and assessment," *Desalination*, vol. 223, no. 1-3, pp. 448–456, 2008.
- [35] R. Borsani and S. Rebagliati, "Fundamentals and costing of MSF desalination plants and comparison with other technologies," *Desalination*, vol. 182, no. 1-3, pp. 29-37, Nov. 2005.
- [36] G. Fiorenza, "Techno-economic evaluation of a solar powered water desalination plant," *Energy Conversion and Management*, vol. 44, no. 14, pp. 2217-2240, Aug. 2003.
- [37] E. Mathioulakis, V. Belessiotis, and E. Delyannis, "Desalination by using alternative energy: Review and state-of-the-art," *Desalination*, vol. 203, no. 1-3, pp. 346-365, Feb. 2007.
- [38] M. Falkenmark and C. Widstrand, "Population and water resources: a delicate balance.," *Population bulletin*, vol. 47, no. 3, pp. 1-36, Nov. 1992.
- [39] P. H. Gleick, "The human right to water," *Water*, vol. 1, no. 1998, pp. 487-503, 1999.
- [40] C. Sullivan, "Calculating a Water Poverty Index," *World Development*, vol. 30, no. 7, pp. 1195-1210, Jul. 2002.
- [41] C. J. Vorosmarty, "Global Water Resources: Vulnerability from Climate Change and Population Growth," *Science*, vol. 289, no. 5477, pp. 284-288, Jul. 2000.
- [42] C. J. Vorosmarty et al., "Global threats to human water security and river biodiversity," *Nature*, vol. 467, no. 7315, pp. 555–561, 2010.
- [43] H. M. L. Chaves and S. Alipaz, "An Integrated Indicator for Basin Hydrology , Environment , Life , and Policy : The Watershed Sustainability Index INTEGRATING THE HYDROLOGY , ENVIRONMENT , LIFE ,," *Response*, 2002.
- [44] S. Pfister, A. Koehler, and S. Hellweg, "Assessing the Environmental Impacts of Freshwater Consumption in LCA," *Environmental Science & Technology*, vol. 43, no. 11, pp. 4098-4104, 2009.

- [45] A. Y. Hoekstra and P. Q. Hung, "Virtual water trade," Delft, Jan. 2002.
- [46] B. G. Ridoutt and S. Pfister, "A revised approach to water footprinting to make transparent the impacts of consumption and production on global freshwater scarcity," *Water*, vol. 20, pp. 113-120, 2010.
- [47] V. Smakhtin, C. Revenga, P. Döll, R. Tharme, J. Nackoney, and Y. Kura, *Taking into account environmental water requirements in global-scale water resources assessments*, vol. 2. Iwmi, 2004.
- [48] V. Smakhtin, M. Iwra, and I. Water, "A Pilot Global Assessment of Environmental Water Requirements and Scarcity," *North*, vol. 29, no. 3, pp. 307-317, 2004.
- [49] D. Molden, "Summary - Water for food, Water for life: A Comprehensive Assessment of Water Management in Agriculture," *Water Management*, no. February, 2007.
- [50] R. Barker, *1990 to 2025 : Scenarios and Issues*. 1990.
- [51] J. Alcamo, T. Henrichs, and T. Rösch, "Global modeling and scenario analysis for the World Commission on Water for the 21st Century," *Kassel World Water Series*, vol. 2, no. 2, 2000.
- [52] J. Alcamo et al., "Development and testing of the WaterGAP 2 global model of water use and availability," *Hydrological Sciences Journal*, vol. 48, no. 3, pp. 317–337, 2003.
- [53] F. R. Rijsberman, "Water scarcity: Fact or fiction?," *Agricultural water management*, vol. 80, no. 1-3, pp. 5–22, 2006.
- [54] "Department of Statistics of The Bahamas." [Online]. Available: <http://statistics.bahamas.gov.bs/key.php>.
- [55] L. Roebuck, T. Ortiz, and J. Pochatila, "Water Resources Assessment of The Bahamas," *Rep. US Army Corps of Engineers*, no. December, 2004.
- [56] F. F. Whitaker and P. L. Smart, "Groundwater circulation and geochemistry of a karstified bank – marginal fracture system , South Andros Island , Bahamas," *Journal of Hydrology*, vol. 197, pp. 293-315, 1997.
- [57] I. Renewable, W. Resources, N. Renewable, W. Withdrawals, and F. F. Species, "Water Resources and Freshwater Ecosystems-- Bahamas Water Resources and Freshwater Ecosystems-- Bahamas," pp. 1-6, 2003.
- [58] J. L. Carew and J. E. Mylroie, "Chapter 3A: Geology of the Bahamas," in *Geology and hydrogeology of Carbonate Islands. Developments in Sedimentology*, 1997.
- [59] H. D. Willauer, D. R. Hardy, and F. W. Williams, "The Feasibility and Current Estimated Capital Costs of Producing Jet Fuel at Sea Using Carbon Dioxide and Hydrogen," Washington, D.C., 2010.

- [60] G. L. Dugger, E. J. Francis, and W. H. Avery, "Technical and economic feasibility of ocean thermal energy conversion," *Solar Energy*, vol. 20, no. 3, pp. 259–274, 1978.
- [61] D. R. Hardy, G. Bresenbruch, and K. Schultz, "Hydrogen as a fuel for DOD," *Defense Horizons*, no. 36, pp. 1-11, 2003.
- [62] L. Hammar and M. Gullström, "Applying Ecological Risk Assessment Methodology for Outlining Ecosystem Effects of Ocean Energy Technologies," *see.ed.ac.uk*, 2011.
- [63] M. Quinby-Hunt, D. Sloan, and P. Wilde, "Potential environmental impacts of closed-cycle ocean thermal energy conversion," *Environmental Impact Assessment Review*, vol. 7, no. 2, pp. 169–198, 1987.
- [64] J. E. Lovelock and C. G. Rapley, "Ocean pipes could help the Earth to cure itself.," *Nature*, vol. 449, no. 7161, p. 403, Sep. 2007.
- [65] G. Boehlert and G. McMurray, "Ecological effects of wave energy development in the Pacific Northwest," *NoAA Tech. Memo.*, p. 174, 2008.
- [66] A. Gill, I. Gloyne-Phillips, K. Neal, and J. Kimber, "The potential effects of electromagnetic fields generated by sub-sea power cables associated with offshore wind farm developments on electrically and magnetically sensitive marine organisms—a review," Silsoe, Bedfordshire, 2005.
- [67] R. FULLER, L. a. Vega, O. Thermal, E. Conversion, K. A. Finney, and O. Circulation, "Ocean thermal energy conversion," *Ocean Management*, vol. 4, no. 2-4, pp. 241-258, Dec. 1978.
- [68] H. Uehara, C. Dilao, and T. Nakaoka, "Conceptual design of ocean thermal energy conversion (OTEC) power plants in the Philippines," *Solar Energy*, vol. 41, no. 5, pp. 431-441, 1988
- [69] D. Cavrot, "Economics of Ocean Thermal Energy Conversion (OTEC)," *Renewable Energy*, vol. 3, no. 8, pp. 891-896, Nov. 1993
- [70] D. Tanner, "Ocean thermal energy conversion: Current overview and future outlook," *Renewable Energy*, vol. 6, no. 3, pp. 367-373, Apr. 1995
- [71] D. Lennard, "The viability and best locations for ocean thermal energy conversion systems around the world," *Renewable energy*, vol. 6, no. 3, pp. 359–365, 1995
- [72] P. J. T. Straatman and W. G. J. H. M. van Sark, "A new hybrid ocean thermal energy conversion–Offshore solar pond (OTEC–OSP) design: A cost optimization approach," *Solar Energy*, vol. 82, no. 6, pp. 520-527, Jun. 2008
- [73] N. Yamada, A. Hoshi, and Y. Ikegami, "Performance simulation of solar-boosted ocean thermal energy conversion plant," *Renewable Energy*, vol. 34, no. 7, pp. 1752-1758, Jul. 2009

- [74] N. J. Kim, K. C. Ng, and W. Chun, "Using the condenser effluent from a nuclear power plant for Ocean Thermal Energy Conversion (OTEC)," *International Communications in Heat and Mass Transfer*, vol. 36, no. 10, pp. 1008-1013, Dec. 2009
- [75] R. Yeh, T. Su, and M. Yang, "Maximum output of an OTEC power plant," *Ocean Engineering*, vol. 32, no. 5-6, pp. 685-700, Apr. 2005
- [76] T. Daniel, "Aquaculture using cold OTEC water," in *OCEANS'85-Ocean Engineering and the Environment*, 1985, pp. 1284-1289
- [77] H. Uehara and Y. Ikegami, "Optimization of a Closed-Cycle OTEC System," *Journal of Solar Energy Engineering*, vol. 112, no. 4, p. 247, 1990
- [78] D. Bharathan, B. K. Parsons, and J. Althof, "Direct-Contact Condensers for Open-Cycle OTEC Applications," Golden, CO, 1988
- [79] T. Rabas, "Production of desalinated water using ocean thermal energy," *Journal of the Electrochemical Society*, vol. 129, p. 2865, 1991
- [80] I. A. Shiklomanov, J. C. Rodda, and others, *World water resources at the beginning of the twenty-first century*. Cambridge University Press Cambridge,, UK, 2003
- [81] V. Smakhtin, C. Revenga, P. Döll, R. Tharme, J. Nackoney, and Y. Kura, *Taking into account environmental water requirements in global-scale water resources assessments*, vol. 2. Iwmi, 2004
- [82] H. Sibly, "Urban water pricing," *Agenda*, vol. 13, no. 1, pp. 17-30, 2006
- [83] F. Kahrl and D. Roland-Holst, "China's water-energy nexus," *Water Policy*, vol. 10, no. 1, pp. 51-65, 2008
- [84] P. H. Gleick, "Basic water requirements for human activities: meeting basic needs," *Water international*, vol. 21, no. 2, pp. 83-92, 1996
- [85] S. L. Postel, G. C. Daily, and P. R. Ehrlich, "Human appropriation of renewable fresh water," *Science*, vol. 271, no. 5250, p. 785, 1996
- [86] L. Ohlsson, "Water scarcity and conflict," in *Documento presentado en New Faces Conference, Forschungsinstitut der Deutschen Gesellschaft für Auswärtige Politik, Bonn, realizado entre el*, 1997, vol. 5, pp. 17-36
- [87] C. Sullivan and J. Meigh, "The Water Poverty Index: Development and application at the community scale," *Natural Resources*, vol. 27, pp. 189-199, 2003
- [88] A. Hoekstra, A. Chapagain, and M. Aldaya, "Water footprint manual: State of the art 2009," no. november, 2009

- [89] D. I. Cho, T. Ogwang, and C. Opio, "Simplifying the Water Poverty Index," *Social Indicators Research*, vol. 97, no. 2, pp. 257-267, Jun. 2009
- [90] L. Garcia-Rodríguez, "Seawater desalination driven by renewable energies: a review," *Desalination*, vol. 143, no. 2, pp. 103–113, 2002
- [91] V. G. Gude, N. Nirmalakhandan, and S. Deng, "Renewable and sustainable approaches for desalination," *Renewable and Sustainable Energy Reviews*, vol. 14, no. 9, pp. 2641-2654, Dec. 2010
- [92] J. K. Kaldellis, K. a. Kavadias, and E. Kondili, "Renewable energy desalination plants for the Greek islands—technical and economic considerations," *Desalination*, vol. 170, no. 2, pp. 187-203, Oct. 2004
- [93] X. Yu, R. Taplin, and T. Akura, "A framework for energy policy-making in the Pacific Islands," *Energy policy*, vol. 25, no. 12, pp. 971–982, 1997
- [94] F. Sinama, F. Lucas, and F. Garde, "Modeling of ocean thermal energy conversion plant in Reunion Island," in *ASME 2010 4th International Conference on Energy Sustainability*, 2010, pp
- [95] P. A. Curto, "An update of OTEC baseline design costs," *Energy*, vol. 5, no. 6, pp. 529-538, Jun. 1980

APPENDIX

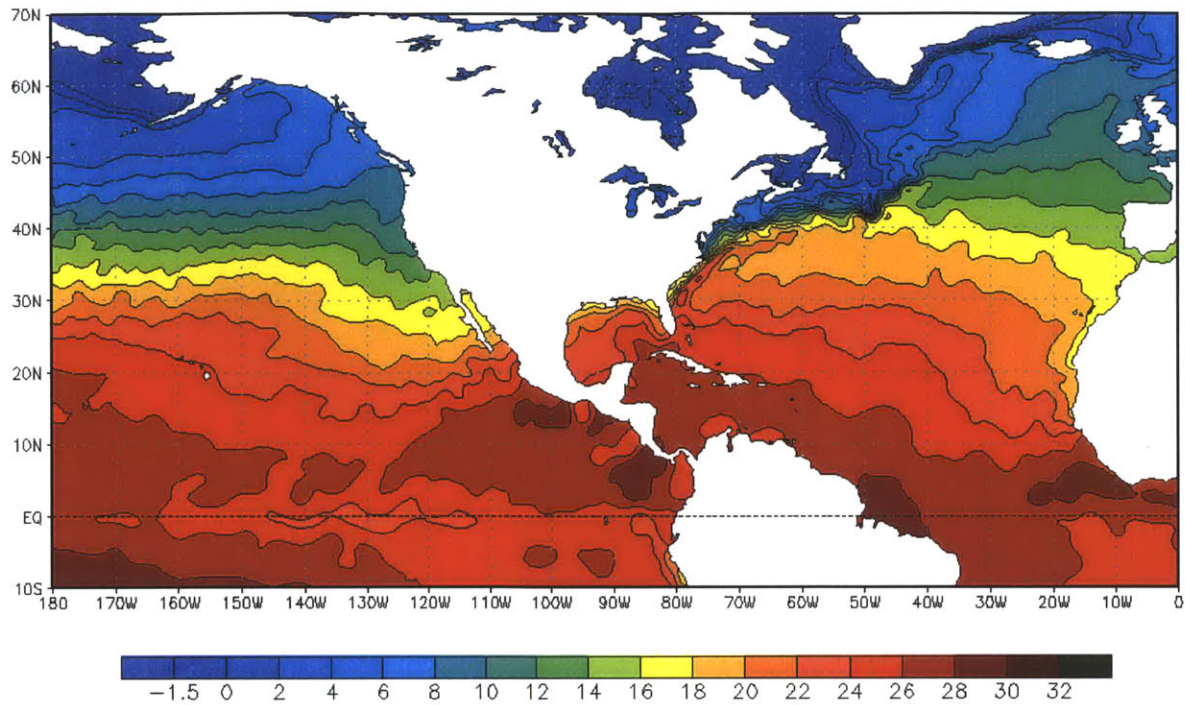

Figure 24: Ocean map of OTEC resource zones around Americas with surface temp. color scale in °C

	LCOE	=	$\frac{(WACC+IWF) \times ICC + LRC + O\&M}{AEP_{net}}$
where:	LCOE	≡	Levelized Cost of Energy (\$/kWh) (constant dollars)
	WACC	≡	Weighted Average Cost of Capital (1/yr)
	IWF	≡	Insurance, Warranty and Fees (1/yr)
	ICC	≡	Initial Installed Capital Cost (\$)
	LRC	≡	Levelized Replacement/Overhaul Cost (\$/yr)
	O&M	≡	O&M Cost (\$/yr)
	AEP _{net}	≡	Net Annual Energy Production (kWh/yr)

Source: [30]

Figure 25: Equation to calculate LCOE

Table 13: Break-up of cost from previous OTEC cost evaluations studies

Plant Size (MW) net	Plant Type	Platform and related systems (\$/kW)	Water ducting systems (\$/kW)	Heat Exchangers systems (\$/kW)	Power generation systems (\$/kW)	Energy transfer systems (\$/kW)	Deployment Installation (\$/kW)	Others (\$/kW)	TOTAL (\$/kW)
40	GE tower-mounted 40MW	4500	3500	1700	1050	0	5250	400	16400
40	Land-based 40MW	2714	3681	3456	1373	225	2439	864	14751
40	Moored plant 40MW	3863	754	1641	441	1340	1201	841	10080
40	Phase IV PREPA 40MW	1050	1110	3140	2720	3300	1000	300	12620
54	OTEC plantship - Closed Cycle 54MW	2318	1570	1776	1196	766	804	0	8430
46	Grazing plantship 46MW	2386	474	1427	383	1397	585	630	7283
200	Methanol plantship 200MW	1468	237	957	235	2396	300	994	6588
386	Ammonia plantship 386MW	985	188	750	184	698	235	423	3463
100	OTEC conventional floating unit 100MW	707	101	1818	859	202	202	152	4040
100	OTEC unit (sub-sea floating vessel) 100MW	616	30	586	869	212	101	131	2545
240	Lockheed Spar-type (AL-tubed) 240MW	1194	550	1030	510	1	64	674	4022

240	Lockheed Spar-type (TI-tubed) 240MW	1211	457	2134	510	0	64	736	5112
500	Ammonia Plant ship - LOCKHEED 500MW	1403	159	5501	556	0	26	1019	8666
500	Ammonia Plant ship 500MW	854	404	980	364	636	13	0	3250
500	Ammonia Plant ship - TRW 500MW	993	311	2681	556	0	13	543	5097
500	OTEC ammonia Plant ship - APL 500MW	530	113	794	556	0	13	424	2430
1	Land-based 1MW	6776	18942	5390	5698	0	0	3080	39886
10	Land-based 10MW	2310	9240	5390	3850	0	0	2310	23100
50	Land-based 50MW	2310	3696	3850	1848	0	0	924	12628
50	Floating (Moored) 50MW	2772	1232	3850	1848	0	0	924	10626

Table 14: Comparison of risk ranking scores for three different ocean energy technologies

Endpoints	Wave	Tidal	OTEC
Marine mammals	40	40	10
Fish (incl. elasmobranches)	22	22	26
Birds	30	30	10
Environment/Habitat	12	16	13
Algae	12	6	14
Epibenthic⁵³ fauna	14	8	6
Plankton	0	0	19
Eggs/Larva	2	2	12
Electrosensitive⁵⁴ fauna	8	8	0
Benthic fauna	4	4	2
Corals	2	2	6

Source: [62]

⁵³ Living on the surface of bottom sediments in a water body

⁵⁴ Sensitive to electric current