



2021

# WHITE PAPER OCEAN THERMAL ENERGY CONVERSION OTEC

**Published by:**

The Executive Committee of the IEA Ocean Energy Systems (OES)

**Edited by:**

Purnima Jaliha, Yann-Hervé De Roeck, Matthijs Soede and Ana Brito e Melo

**Designed by:**

Formas do Possível | [www.formasdopossivel.com](http://www.formasdopossivel.com)

**Cover:**

South Korea's "K-OTEC1000" Floating OTEC Plant Successfully Deployed in 2019

**Suggested Citation:**

OES (2021), White Paper on Ocean Thermal Energy Conversion (OTEC), IEA Technology Programme for Ocean Energy Systems (OES), [www.ocean-energy-systems.org](http://www.ocean-energy-systems.org)

**Disclaimer:**

The OES, also known as the Technology Collaboration Programme for Ocean Energy Systems, functions within a framework created by the International Energy Agency (IEA). Views, findings and publications of OES do not necessarily represent the views or policies of the IEA secretariat or its individual member countries.

# PREFACE AND ACKNOWLEDGMENTS

This White Paper was developed as a task under the International Energy Agency's Ocean Energy Systems Technology Collaboration Programme (OES) to provide for Policymakers and Developers an update on the potential of Ocean Thermal Energy Conversion (OTEC), its history, present state of development and future prospects.

This document was prepared by Martin G. Brown of Ocean Energy Systems Limited (OESL) of Aberdeen, Scotland, under the guidance of the OTEC Steering Committee consisting of:

- Dr. Purnima Jalihal, National Institute of Ocean Technology (NIOT), Chennai, India
- Prof. Yasuyuki Ikegami, Institute of Ocean Energy, Saga University, Japan
- Dr. Hyeon-Ju Kim, Seawater Energy Plant Research Center, Korea Research Institute of Ships and Ocean Engineering (KRISO), South Korea
- Associate Prof. Ji Wang, National Ocean Technology Centre, Tianjin, China
- Mr. Song Zhang, National Ocean Technology Centre, Tianjin, China
- Prof. James Van Zwieten, Department of Civil, Environmental and Geomatics Engineering, Florida Atlantic University, USA
- Dr. Yann-Hervé De Roeck, France Energies Marines, France

## List of Abbreviations

<b>CAPEX</b>	Capital Expenditure	<b>NELHA</b>	National Energy Laboratory of Hawaii Authority
<b>CO<sub>2</sub></b>	Carbon Dioxide	<b>NH<sub>3</sub></b>	Ammonia
<b>CWP</b>	Cold Water Pipe	<b>OPEX</b>	Operating Expenditure
<b>DOW</b>	Deep Ocean Water	<b>OTEC</b>	Ocean Thermal Energy Conversion
<b>DOWA</b>	Deep Ocean Water Applications	<b>SWAC</b>	Sea-Water Air Conditioning
<b>FLNG</b>	Floating Liquefied Natural Gas Unit	<b>TRL</b>	Technology Readiness Level
<b>FPSO</b>	Floating Production Storage and Offloading Unit	<b>SIDS</b>	Small Island Developing States
<b>HDPE</b>	High Density Polyethylene		

# TABLE OF CONTENTS

## 1.

<b>Introduction</b> .....	<b>06</b>
1.1 What is Ocean Thermal Energy Conversion (OTEC) .....	06

## 2.

<b>Summary of Key Points</b> .....	<b>08</b>
------------------------------------	-----------

## 3.

<b>Deep Ocean Water Resource</b> .....	<b>10</b>
3.1 Thermal (OTEC) Resource.....	10
3.2 Tropical Areas not subject to Hurricanes and Typhoons.....	11
3.3 Nutrient Rich Deep Ocean Water.....	11

## 4.

<b>OTEC History and Worldwide Project Development Status</b> .....	<b>12</b>
4.1 Summary of OTEC's Long Development and Testing History .....	12
4.2 "OTEC-1" - Particularly Significant Past Project.....	14
4.3 Status of Present and Planned OTEC Projects.....	14

## 5.

<b>Thermal Resource Utilisation Options</b> .....	<b>16</b>
5.1 Land, Shelf Based and Floating OTEC Power Plants .....	16
5.2 Power Export from Floating OTEC.....	18
5.3 Deep Ocean Water (DOW) Associated By-Products.....	18
5.4 Seawater Air Conditioning (SWAC).....	19

# 6.

<b>Main OTEC Power Generation Cycles</b> .....	<b>20</b>
--	-----------

# 7.

<b>Environmental Impact of OTEC</b> .....	<b>22</b>
<b>7.1</b> Environmental Impact – Emissions .....	22
<b>7.2</b> Environmental Impact – Upwelling of Nutrient Rich Deep Clean Water .....	22
<b>7.3</b> Established History of Environmental Monitoring .....	23

# 8.

<b>Technology Development Status</b> .....	<b>24</b>
<b>8.1</b> OTEC Power Cycle Equipment .....	24
<b>8.2</b> OTEC Engineering Standards .....	25
<b>8.3</b> Cold Water Pipe (CWP) Technical Status .....	25
<b>8.4</b> Circa 2.5 MW Land Based OTEC Technically Achievable Today .....	25
<b>8.5</b> 10 MW Floating OTEC Technically Achievable Today .....	26
<b>8.6</b> Floating OTEC Utilising Oil and Gas Floating Production Technology and Redundant Vessels .....	26

# 9.

<b>Road-Blocks to Development</b> .....	<b>27</b>
<b>9.1</b> Absence of a 2.5+ MW Demonstration Unit .....	27
<b>9.2</b> High CAPEX/LCOE Estimates for Prototypes up to 100 MW Size .....	28
<b>9.3</b> Lack of Incentives to Overcome the Innovation Valley of Death .....	29
<b>9.4</b> Lack of OTEC Knowledge within Governments and the General Public .....	29

# 10.

<b>Recommendations for Policymakers</b> .....	<b>30</b>
---	-----------

# 11.

<b>Conclusions</b> .....	<b>32</b>
--------------------------	-----------

# 12.

<b>References</b> .....	<b>34</b>
-------------------------	-----------

# 1.

## INTRODUCTION

### 1.1 What is Ocean Thermal Energy Conversion (OTEC)

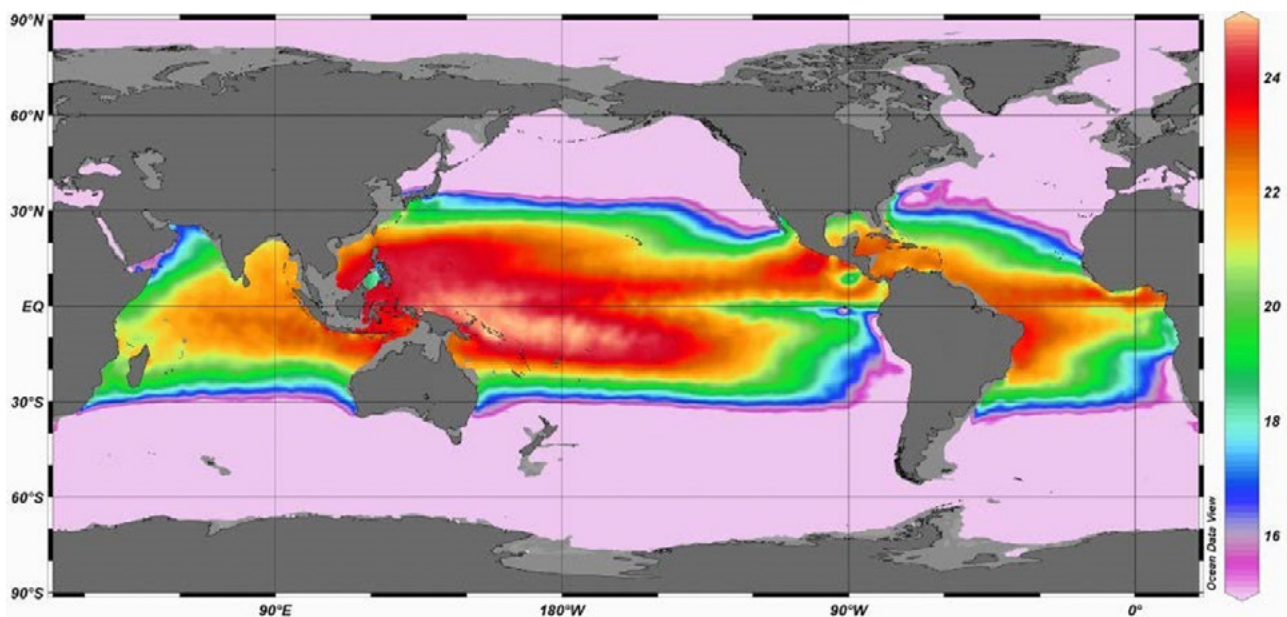

Figure 1.1 Mean annual temperature difference between the typical OTEC depths of 20 and 1000 m (Nihous, C.C., 2010)

In the tropical oceans, sun light warms the surface layer to more than 25°C depending on location. This causes a boundary between the less dense warm water with the colder and denser deeper ocean water, see Figure 1.1, which shows this yearly averaged temperature difference over the globe. This oceanographic process is termed the thermocline and an example thermal profile is illustrated in Figure 1.2.

Ocean Thermal Energy Conversion (OTEC) uses this temperature difference to produce electricity, as illustrated in Figure 1.3. Warm seawater causes a low

boiling point liquid, such as ammonia to vaporise, which drives a turbine to generate electricity with the vapour condensed by cold deep seawater. More explanation of this thermodynamic process can be found in section 5.

Since the ocean comprises around 70% of the earth's surface it is a vast receiver and repository of solar energy. While waves, winds, tides and currents are all forms of ocean renewable energy, which vary with time and season, conversely, an OTEC system permits the generation of constant power 24 hours a day, 365 days a year.

Effectively the tropical ocean is acting as a gigantic thermal battery. The cold deep ocean water from the north and south poles circulates worldwide and acts as a heat sink. OTEC technologies thereby provide a clean and renewable source of energy. OTEC has some similarities to solar power, however, the technology does not require solar panels over the sea surface, since the process makes use of the heat absorbed by seawater, not by a panel.

At present, OTEC plants, based on one-off projects, are relatively capital intensive. However, because the OTEC power cycle is relatively simple with modest operating pressures, this typically results in low operational, maintenance (O&M) and manning costs. Over time it is expected that OTEC power generation costs will decrease due to economies of scale and mass production, as has been seen with the offshore wind industry. OTEC technology is very well suited for mass production using established manufacturing infrastructure such as large shipyards, modern factories for turbines, pumps, heat exchangers, etc.

Unlike other renewable energy sources, such as wind and waves, OTEC is not well known. This is partly because it is not immediately apparent how power can be extracted from the thermal gradients. By comparison, it is obvious that a wind turbine generates power by wind rotating the

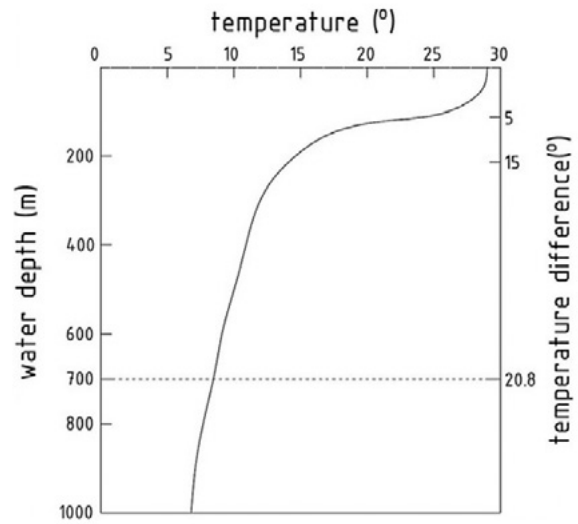

Figure 1.2 Typical tropical ocean temperature change versus water depth (Thermocline), (Adiputra et al, 2020)

blades. Hence, there is an important need to educate both the public and policymakers about how OTEC works, its major potential, and its numerous associated benefits.

Overall OTEC is an energy production process that has high growth potential and could aid the economic development of tropical and industrialised nations, while also reducing carbon dioxide emissions.

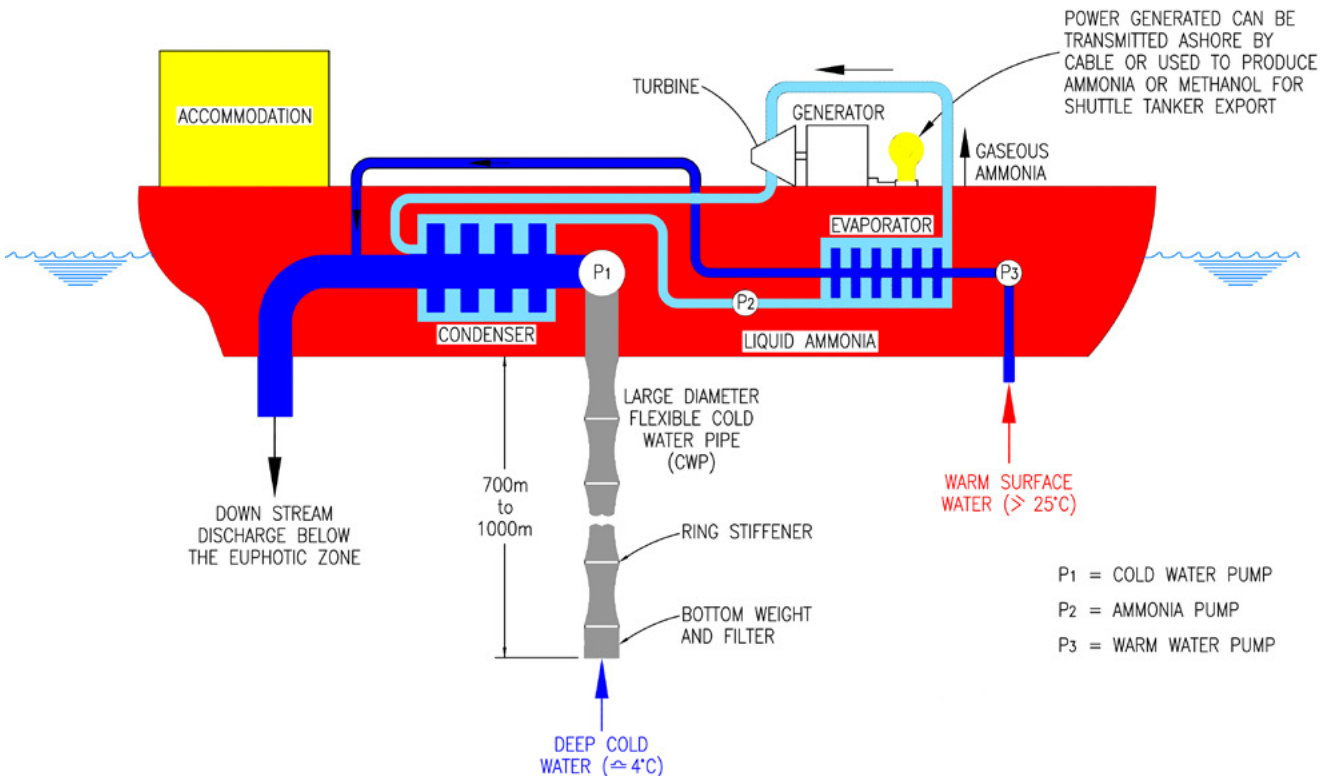

Figure 1.3 Illustration of a floating closed cycle OTEC system (copyright M. Brown, OESL)

# 2.

## SUMMARY OF KEY POINTS

### **OTEC is a Base Load Power Source with Vast Potential**

The tropical oceans act as a vast solar collector and the OTEC process allows this to be converted to clean electricity without interruption, 24 hours a day, 365 days a year. It has been calculated using conservative assumptions that OTEC's worldwide maximum power output could be as high as 8,000 GW (Nihous, 2018). This is more than the world's present electricity production. Thus, OTEC has the potential to make a major contribution to the energy transition process and worldwide decarbonisation.

### **Additional OTEC Co-Products including the Production of Fresh Water**

In addition to generating electricity, the OTEC power cycle can be configured to also produce freshwater during the energy production process. For many tropical locations, fresh water is a scarce, critical and valuable commodity. Very significantly, the deep ocean water is also rich in nutrients, which can be used to promote aquaculture. The still cool water from an OTEC plant can be used for large-scale air conditioning, which can save somewhere in the region of 90% of typical air conditioning power consumption. The cool water can also be used for temperature-controlled agriculture – see sections 5-6. Particularly for deep sea floating OTEC plants, the pumping (artificial upwelling) of nutrient rich deep water may boost the production of algae, which may result in carbon dioxide removal (CDR) from the atmosphere – see section 6.

### **Simple and Reliable Technology Proven in Hawaii and Japan**

The OTEC process is simple with relatively low operating pressures. Simplicity typically results in high equipment up times and high reliability, as has been seen by the OTEC plants operating in Hawaii and Japan, Kumejima Island (see Figure 2.1). Thus, there is a well-established track record of infield performance, although presently at a relatively small scale.

### **Minimal Platform Intrusive Footprint with Demonstrated Durability**

Unlike wind (land-based or floating) or solar power (land-based or floating) the footprint requirements for OTEC plants are small. The oil and gas floating production experience has demonstrated that floating facilities can be built which are durable and long lasting. Floating OTEC ships can be dry-docked when required, thus increasing the life of the facilities and reducing the cost of difficult, and sometimes hazardous, offshore hull maintenance and process equipment overhaul.

### **2.5+ MW Multi-Product OTEC Potential for Small Island Developing States (SIDS)**

The present state of proven pipeline technology is such that an island-based 2.5 MW system is achievable today – see section 8.4. A multi-product eco-resort including clean and green energy, freshwater, aquaculture, air-conditioning, etc., is an attractive concept for SIDS, but support via a feed-in tariff is typically still required for such a system to show an acceptable return on capital investment. This is because the cost of required seawater pipelines is quite high, for relatively low power output. The present pipeline deployment size limit is related to minimising the deployment cost by using standard equipment; larger pipes are possible, but with a potential steep increase in installation cost.



**Figure 2.1**  
Closed cycle Okinawa OTEC  
demonstration facility on  
Kumejima Island  
(Courtesy: Okinawa Prefecture  
Industrial Policy Division)



### **10 MW Floating OTEC is Technically Achievable but Not Yet Commercial**

Considering the significant technical developments over the last 15 years in the oil and gas deep water floating production market, including floating liquified natural gas (FLNG), it is judged to be technically feasible to build a 10 MW net floating OTEC plant today – see section 8.5. At this still relatively limited power output it is difficult for such a prototype project to be attractive to the private sector alone. Investors would be more willing to commit to such a project if supportive feed-in tariffs are available.

### **Government Support Required for a Demonstration Plant of 2.5+ MW**

At present established Energy Companies and Impact Investors are keen to invest in renewable energy projects if they show good potential for the future and are perceived to be of low technical risk. Hence, there is a need for international government support to encourage the building of a demonstration plant to obtain operating performance data at a scale of 2.5 MW plus for a minimum period of one or two years – see section 8.4. This support could be via feed-in tariffs or other fiscal incentives, such as low interest rate loans, free access to coastal land, use of government oceanographic survey vessels, navy support for installation, etc.

### **What is Missing to Scale up to 100+ MW?**

Currently, the main challenge to scaling up to 100 MW or more for a floating OTEC plant is confidence that large diameter cold water intake pipes can be installed and will prove reliability over time. In practice, the experience gained from building and operating a 10 MW floating OTEC plant will allow engineers and material specialists to identify suitable designs for larger-scale plants. Full-scale experience from the 10 MW plant will allow accurate simulations to be developed for numerically evaluating large-scale proposed designs before construction.

### **The Long-Term Potential for OTEC**

If investment returns are attractive, the long-term potential for large-scale non-moored “grazing” OTEC ships is enormous. This is likely to require hydrogen, ammonia or methanol to be synthesized offshore and then exported via dedicated shuttle tankers which would be somewhat similar to those used with FPSOs – see section 8.6. Existing infrastructure such as shipyards and oil and gas manufacturers can be repurposed to work on floating OTEC facilities. Hence economic opportunities are substantial, including reduction in carbon dioxide emissions. Shipyards and manufacturers could be optimised for serial production of OTEC ships, turbines, pumps, sea-water pipes and associated ammonia or methanol (hydrogen) carrying shuttle tankers.

### **Need for Publicity and Education on OTEC’s Potential and Benefits**

While relatively high capital cost estimates have impeded OTEC commercial developments, another significant factor has been a lack of knowledge and understanding within the public, governments and the investment community. Given the major challenges associated with achieving the size of the required global energy transition away from hydrocarbons, it is apparent that OTEC and its potential deserves and requires more awareness. This will help attract support for measures such as feed-in tariffs to speed up the adoption of this major green power resource.

### **Environmental & Ecological Impact**

If discharge water is released at equivalent temperature depths, it is envisaged that environmental & ecological impacts to ocean over long period is negligible. The existing small rating plants do not show adverse impacts, however, scaling up and its effect will need further detailed study.

# 3.

## DEEP OCEAN WATER RESOURCE

### 3.1 Thermal (OTEC) Resource

In general terms, an adequate temperature difference between the surface and sub-surface layers can be found in the tropical oceans between 23 degrees north to 23 degrees south. This gives a vast potential area available for OTEC. To give some context, this potential area is equivalent to nine Sahara Deserts, and the Sahara Desert itself is almost the size of Europe.

Using conservative assumptions, with respect to potential placing floating OTEC plants to not significantly disrupt marine ecosystems, the theoretical worldwide OTEC maximum power output is estimated at 8,000 GW (Nihous, 2018). This highlights the mammoth potential of the resource, even, if a small percentage is harnessed initially.

The following is apparent from the oceans' thermal gradients, as shown in Figure 1.1:

- The central and western Pacific Ocean has an annual average temperature difference of above 24°C and countries in this region, such as Indonesia, Malaysia, the Philippines and many Pacific Island countries can obtain deep cold water in nearby offshore waters. Thus, the region possesses excellent conditions for the development and exploitation of OTEC.
- The east coast of Central America in the western Atlantic and the coastal areas around the Gulf of Guinea have good thermal gradients. Countries in this region such as Mexico, Brazil and some African countries are also well suited for developing ocean thermal energy resources.

- The islands of the Caribbean, the east coast of the Indian Ocean, and the South China Sea, as well as countries such as India and China also possess suitable conditions for developing ocean thermal energy.

An informative graph to help understand better the distribution of warm surface and colder deeper water around the globe is included in Figure 3.1. This figure shows a vertical slice or meridional section through the oceans where the black peaks represent sea-bed contours running from 54° south to 55° north. This P16 meridional section passes through the Hawaiian Islands, where the solid black strip denotes the islands which rise above the sea surface. The lower of the two graphs clearly show that the warm layer is relatively shallow compared to the much deeper colder water layers. Of course, the area of the warm surface layer is vast when you consider the three-dimensional surface of the tropical ocean. The lower graph highlights that the volume of the cold water sink is truly massive, which has significant implications for global warming.

Looking at the upper graph of Figure 3.1 it is interesting to note that for the typical OTEC band of approximately 25°C north to 25°C south “light blue” 2°C to 5°C water is accessible from 800 to 900 m rather than the normally quoted 1000 m water depth. Reducing the length of the required CWP saves capital cost and thus should improve economic feasibility.

In certain places, an annual mean temperature difference above 20°C can be achieved at shallower cold water intake depths, including locations where the total water depth is less than 1000 m. For example, a 20.15°C mean temperature difference was found off Indonesia for a cold water intake depth of 300 m and a 23.3°C mean temperature difference was found off Papua New Guinea for a cold water depth of 600 m (Rauchenstein, 2012).

### 3.2 Tropical Areas not subject to Hurricanes and Typhoons

Hurricanes, typhoons and cyclones are all forms of tropical revolving storms which, depending on severity, could damage an OTEC facility. Although oil and gas facilities have been built which can withstand such storms, the required strength tends to be expensive. To keep the CAPEX of an OTEC facility low and improve its economic viability it is desirable to avoid intense tropical storms. Fortunately there is a band of ocean around the equator which is in general free of tropical revolving storms. Hence, depending on the location of a proposed plant, it may be possible to design a significantly cheaper facility if it will always be in benign environmental conditions. This is particularly relevant for initial prototype units.

### 3.3 Nutrient Rich Deep Ocean Water

Apart from the overriding requirements of sufficient light for photosynthesis, ocean productivity is affected by numerous other factors of which the two most important are temperature and nutrient supply. Although temperature speeds up biological processes, if no nutrients are available there will be little phytoplankton production. A significant factor regarding temperature is its effect on the stability of the water column. If there is no mixing between the cold deep water and warm shallow water, this will restrict the supply of nutrients to the surface layers.

The sub-tropical and tropical OTEC regions have temperature and light levels in their surface layers which could allow phytoplankton production to occur throughout the year. However, the stable thermocline has an adverse effect on phytoplankton production since there is very little vertical motion of the water. Thus, there is some justification in describing the **deep blue tropical waters as the deserts of the oceans**. Section 6.2 discusses the implications for biological productivity and the potential impact on carbon dioxide levels of bringing up large quantities of nutrient rich water as part of the OTEC process.

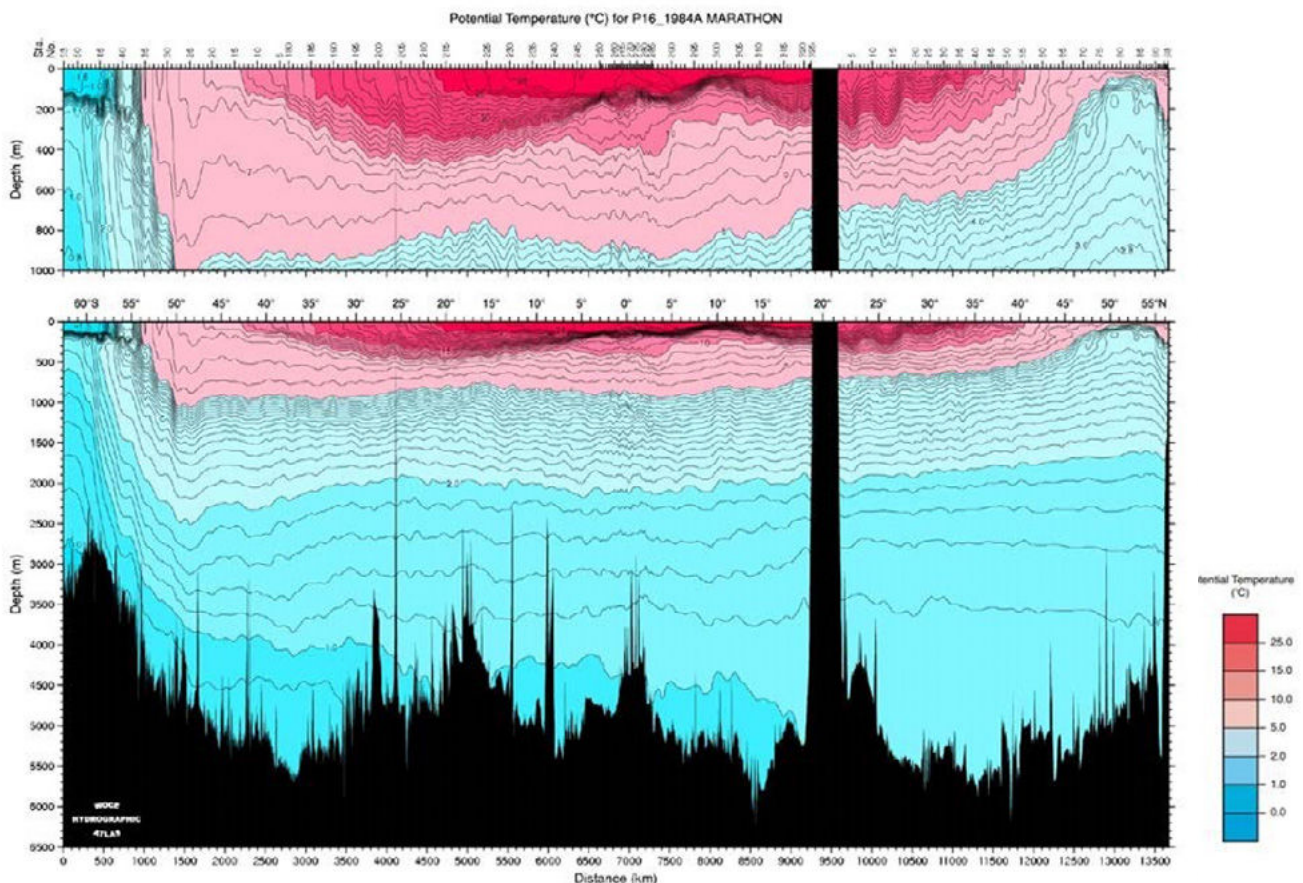

Figure 3.1 P16 Meridional section from 54° south to 55° north (Talley, 2007)

# 4.

## OTEC HISTORY AND WORLDWIDE PROJECT DEVELOPMENT STATUS

### 4.1 Summary of OTEC’s Long Development and Testing History

Research work on OTEC is presently being carried out by several countries with the most significant being South Korea, Japan, India, France, China, Malaysia and the USA.

A history of several important international development projects is detailed in Table 4.1 and Figure 4.1. Considerable progress has been made over the years and up to the present date. To avoid reinventing the wheel it is important

that researchers make full use of the large body of existing public domain data and experience to move forward and avoid some of the problems encountered in the past. For example, a number of CWPs have been lost during the pipeline deployment process, although not during the last decade.

No.	Agency/company (Country)	Year, Location	Power Rating (kW)	
			Gross	Net
1	Claude (France)	1930, Cuba	22	-
2	Mini OTEC (US)	1979, Hawaii	53	18
3	OTEC-1 (US)	1980, Hawaii	1000	-

4	Toshiba & TEPC (Japan)	1982, Nauru	120	31.5
5	Saga University (Japan)	1984, Saga	75	-
6	NELHA (US) Open Cycle	1992, Hawaii	210	100
7	Saga University (Japan)	1995, Saga	9	-
8	NELHA (US)	1996, Hawaii	50	-
9	NIOT (India)	2000, Tuticorin (incomplete)	1000	-
10	Naval Group (France)	2012 onwards, La Reunion Island	15	
11	KRISO (South Korea)	2012, Goseong	20	
12	Okinawa Prefectural Government (Japan)	2013/2016, Kumejima, Okinawa prefecture, Japan	100	
13	Makai Ocean Engineering, Hawaii USA,	2015, Kona, Hawaii	100	-
14	K-OTEC1000 Barge, (KRISO) South Korea	2019. Floating unit	338 to 1000	

Table 4.1 Summary of key OTEC research and development projects

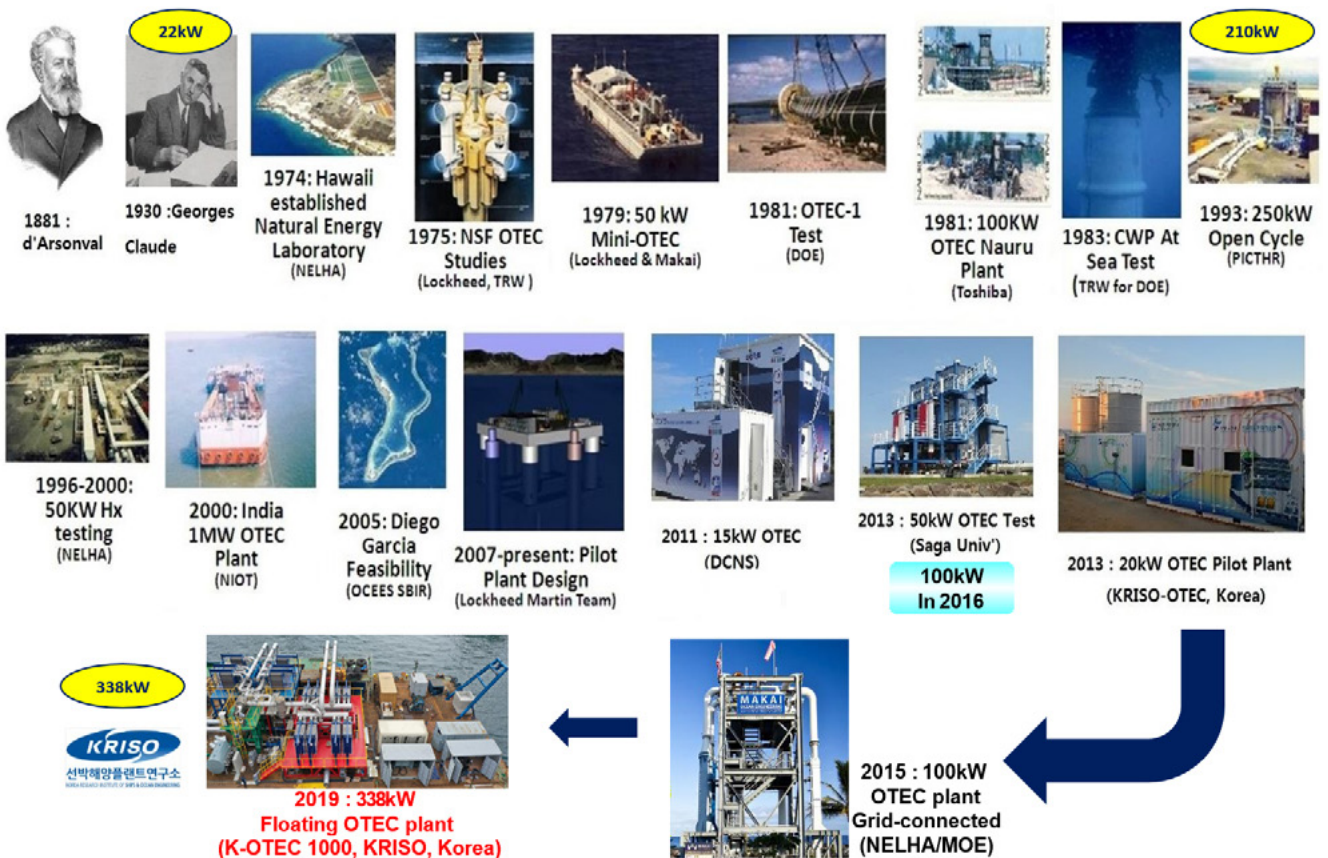

Figure 4.1 Illustration of OTEC's long development and testing history (Courtesy: KRISO)

## 4.2 “OTEC-1” - Particularly Significant Past Project

The US Department of Energy’s OTEC-1 project is particularly significant since it was successfully proved using early 1980s technology, the main elements of a larger scale (1 MW test loop) floating OTEC system (Figure 4.2). The project utilized a converted 160 m long redundant tanker (US Navy, dating from WW2) with turbo-electric main propulsion. In particular, the project proved the feasibility of horizontal launching (Figure 4.3), towing, successfully mating (Figure 4.4) to the underside of the tanker a bundle of three HDPE Cold Water Pipes, plus later disconnection. A special motion decoupling gimbal was used (Figure 4.5). The successful nature of the OTEC-1 project led to Senator Spark M. Matsunaga describing the project as “*the most important ocean energy experiment ever conducted by the United States Government.*”

This project provides confidence that if, in particular, the skills of the oil industry are utilised, it is possible to design and install successfully larger CWP. As is discussed in section 8.3 a key uncertainty for OTEC has been whether CWP can be designed and successfully installed.

## 4.3 Status of Present and Planned OTEC Projects

KRISO undertook a survey in 2019 of worldwide operational and planned OTEC projects. Figure 4.6 summarises the results of the survey. These OTEC power plants range in net power production from 15 kW to 20 MW. It can be seen from this illustration that, at present, there is significant worldwide interest in OTEC and Sea-water Air Conditioning (SWAC) systems – See section 5.4 for technical discussion on SWAC systems.

### Most Recent Projects:

- Korean Research Institute of Ships and Ocean Engineering (KRISO) is planning to relocate the K-OTEC 1000 barge OTEC power cycle equipment (see cover picture) to Tarawa, Kiribati island during 2021-22.
- An OTEC plant built by Makai Ocean Engineering became operational in Hawaii in August 2015. This is the first closed-cycle OTEC plant to be connected to a U.S. electrical grid. It is a demonstration plant capable of generating 105 kW, enough to power about 120 homes.



Figure 4.2 OTEC-1 facility in Honolulu (ex US Navy WW2 Turbo Electric T2 Tanker)



Figure 4.3 Horizontal launch of the OTEC-1 cold water three pipe bundle, Big Island of Hawaii



Figure 4.4 Vertical mating of the OTEC-1 cone CWP offshore Hawaii

- In 2013/2016 in Japan, a 100 kW OTEC demonstration facility was established by Okinawa Prefecture with technical assistance from Saga University through a subcontract to IHI Plant Construction, Yokogawa Electric, and Xenosys Inc. This is a grid-connected unit, which is still operational.

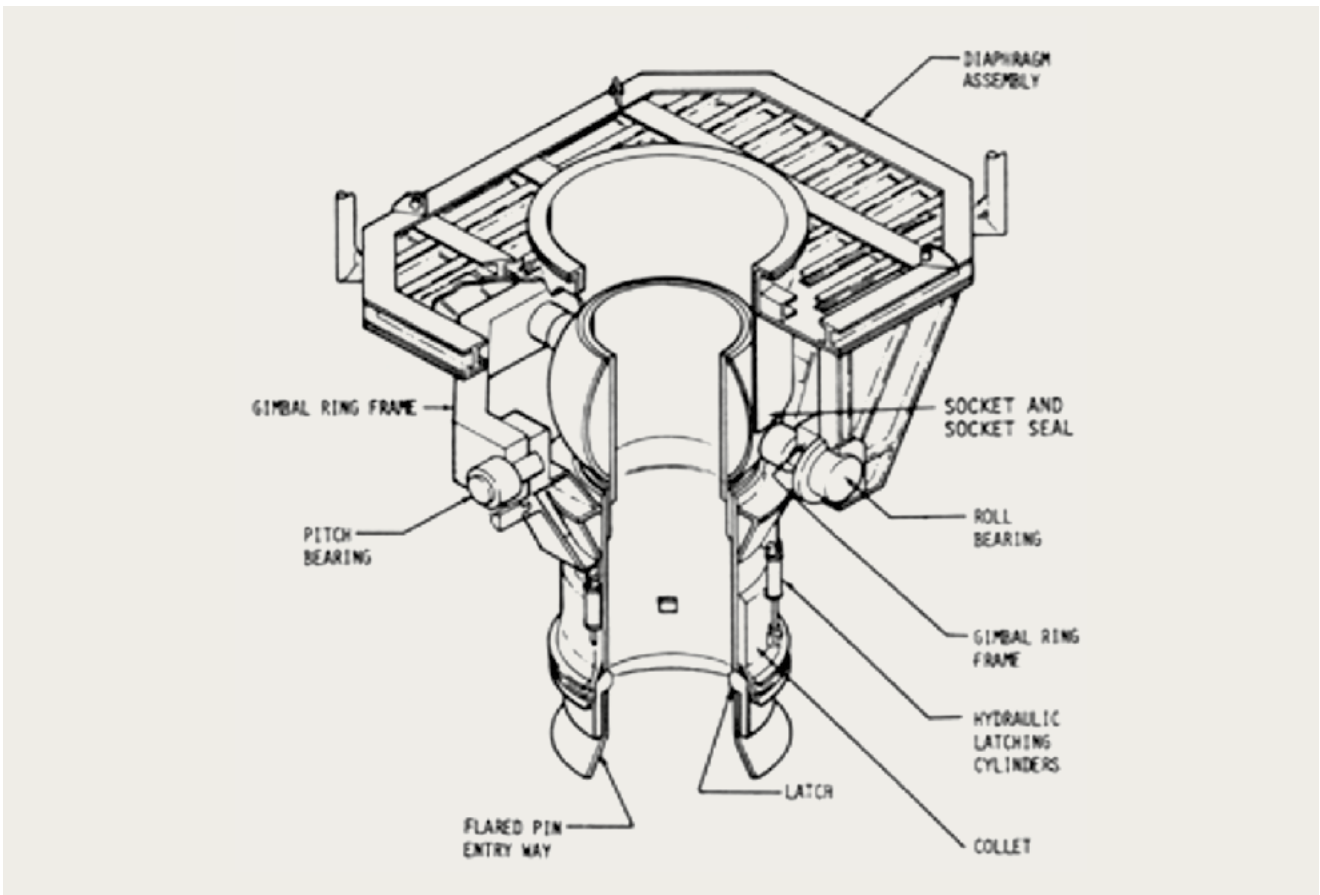

Figure 4.5 Motion Decoupling Gimbal Connection

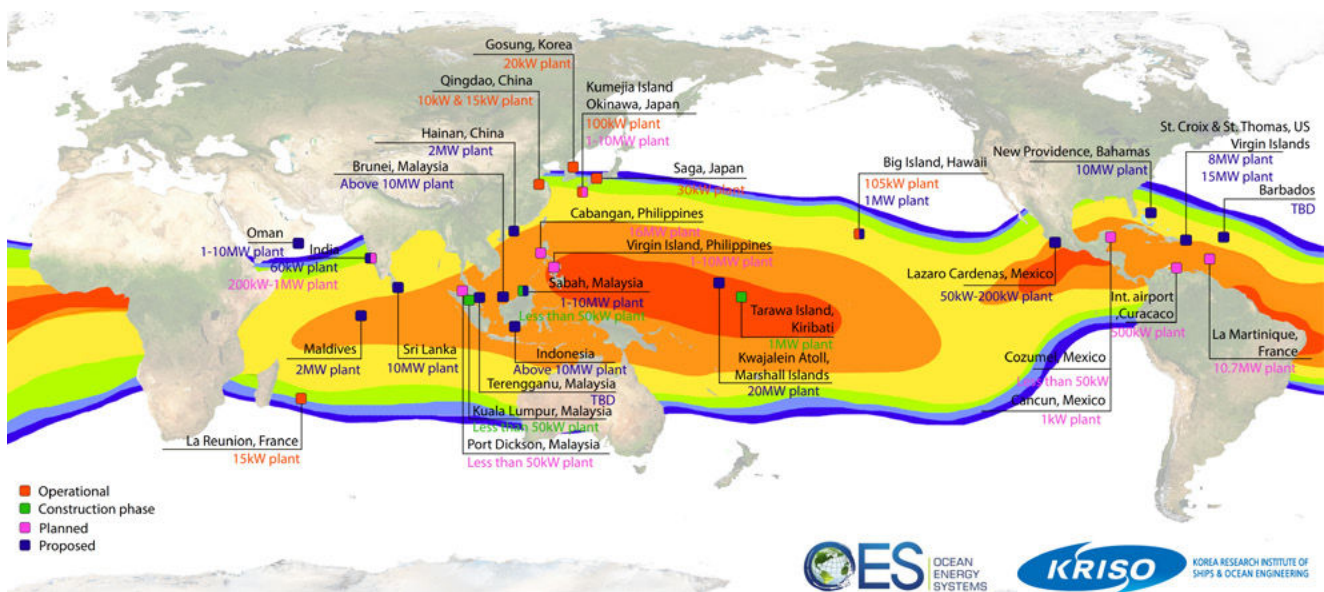

Figure 4.6 Present and future planned OTEC/SWAC projects around the world

# 5.

## THERMAL RESOURCE UTILISATION OPTIONS

### 5.1 Land, Shelf Based and Floating OTEC Power Plants

The location for an OTEC plant is selected based on criteria including proximity to warm and cold seawater with a typical annual average minimum temperature difference of 20°C, a demand for power and/or fresh water and an acceptable estimated cost for transmitting the produced

electricity and other possible byproducts. OTEC power plants can be installed using three basic configurations depending on the location: (a) Land-based plant, (b) Shelf mounted plant and (c) Floating plant.

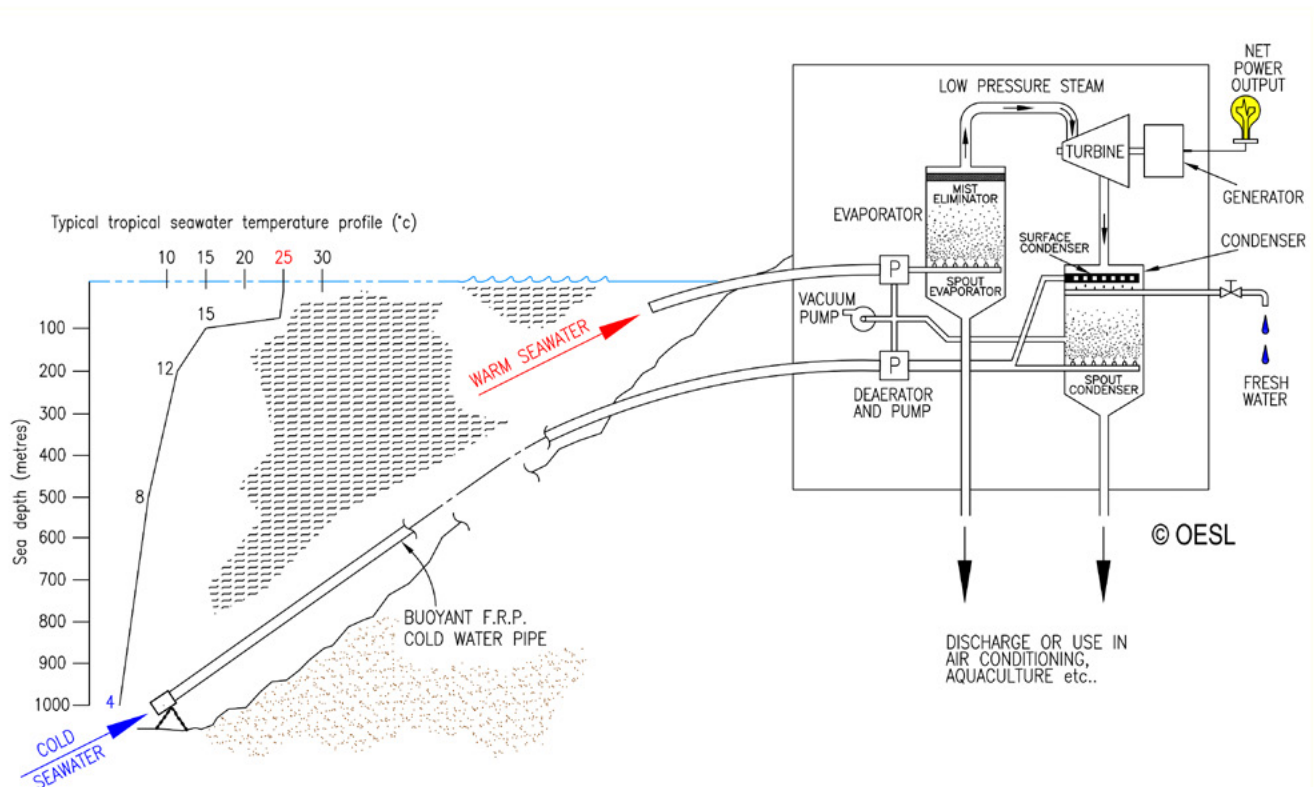

Figure 5.1 Land based open cycle (OC) OTEC including fresh water production (copyright M. Brown, OESL)



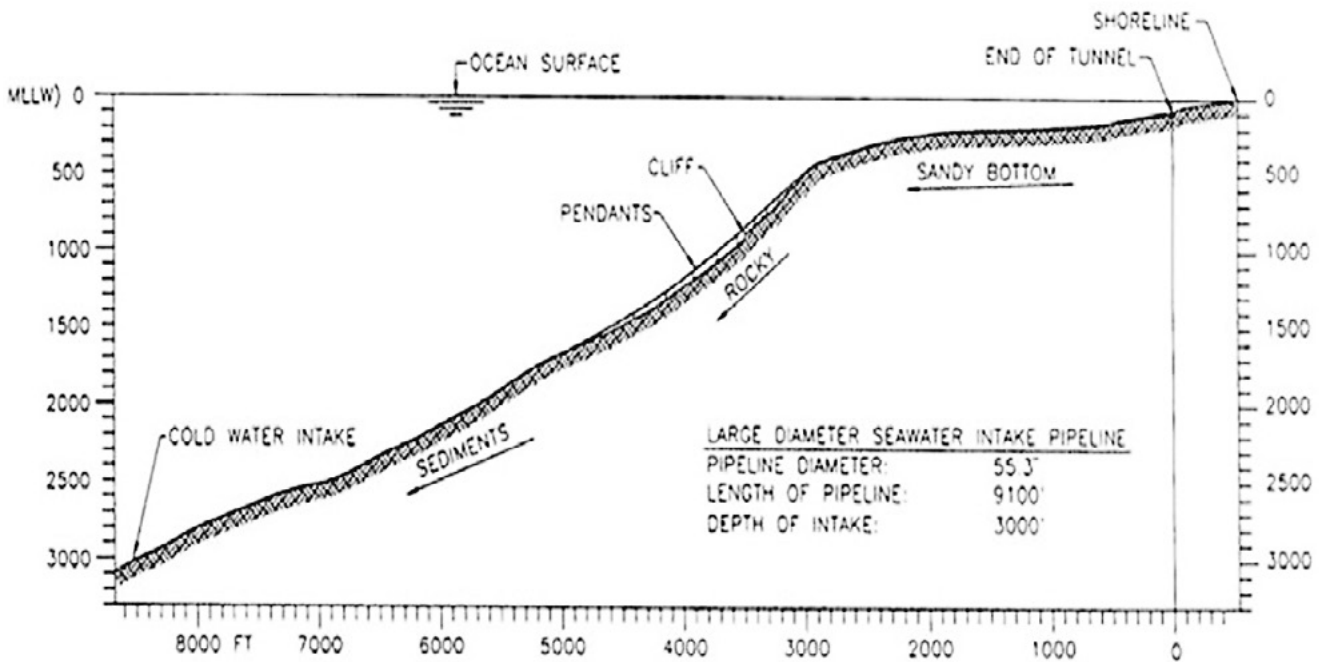

Figure 5.2 NELHA 1.4 m (55 inch) CWP (note Directional Drilling and Micro Tunnelling for the Shore Crossing)

### 5.1.1 Land Based Plants

This type of plant is preferred when the source of deep-sea cold water is available at a relatively short distance from the coast. It offers advantages over plants located offshore such as not requiring mooring systems and lengthy power cables, reduced maintenance costs compared to offshore plants and easier transmission of resulting products, such as electricity and fresh water, to the respective grid and water networks. There is also potential for district cooling and onshore agri/aquaculture – see section 5.3. Despite these advantages, land-based plants face the challenge of wave and current action in the nearshore zone influencing the design, robustness and hence cost of the intake and discharge seawater pipes. Figure 5.1 and Figure 5.2 show the main components of a land-based system.

### 5.1.2 Shelf Mounted Plants

In regions where there is a long continental shelf presenting a gradual slope, OTEC plants can be mounted at the edge of the shelf at depths of up to about 100 m. This type of plant can be piled to the seabed, similarly to the manner used for conventional bottom-mounted offshore oil platforms. Such a design allows the OTEC machinery to be

closer to the cold water source saving seawater piping costs. However, this type of installation provides new CAPEX and OPEX challenges depending on the distance of the platform from the shore. It is also necessary to address energy plus possible fresh-water transmission to the shore, fabrication and installation challenges. Relative to land-based plants ocean facilities are associated with higher operational expenditure. Still, this is an option for particularly African or Central American coastal nations with continental shelves.

### 5.1.3 Offshore Floating Plants

An OTEC plant can be located on a floating platform/ship where the deep cold water is readily accessible directly underneath the hull. This significantly reduces the required length of the CWP compared to a land-based system. Offshore floating platforms are expected to be the gateway to large-scale commercial OTEC plants. Proven technologies from oil and gas floating production units have demonstrated that some hull forms present viable and attractive options. Floating platforms have their own challenges; the platforms must be designed for wind, wave and current conditions as well as for desired low platform motion responses, which are important for maximizing OTEC energy production up time.

## 5.2 Power Export from Floating OTEC

Offshore floating production units are frequently moored to the seabed with either turrets (weather-vaning units) or spread moorings. The power and possibly fresh water from a moored offshore OTEC plant will most likely be transported to the nearest shore via subsea power cable and flexible riser (Figure 5.3). Fixed and floating offshore wind systems have successfully demonstrated high-power offshore transmission cables. However, the required cable length influences purchase and installation costs.

For OTEC to become a truly major international energy provider, large-scale floating units will be required. These units may be “grazing,” non-moored production ships located in international waters using the mixed warm and cold water discharge for propulsion, a form of Dynamic Positioning (DP). Such grazing units are likely to seek out the best ocean temperature difference based on updates from orbital satellites. These floating units may synthesise either ammonia or methanol offshore as a hydrogen energy carrier, to permit power export to industrialised markets. Liquid ammonia or methanol can be transferred to dedicated shuttle tankers as shown in Figure 5.4. It is worth noting that there is an established market for transporting ammonia around the world, for example, see the ammonia tank barge in Figure 5.5.

## 5.3 Deep Ocean Water (DOW) Associated By-Products

During power generation, an OTEC plant will pass large quantities of warm and cold seawater through its heat exchangers. Additional benefits can be gained from this water, which can improve the economic viability of an integrated OTEC system. A key by-product generated by an open-cycle OTEC or hybrid OTEC plant is fresh, desalinated water. In many tropical locations both electricity and clean drinking water are scarce and expensive.

Seawater aquaculture using nutrient rich, pathogen free, cold deep seawater for enhanced fish farming and algae production is a viable spin-off from the electricity production process (Figure 5.6). Cold deep seawater discharged from OTEC condensers can also be used for district cooling, sometimes called Seawater Air Conditioning (SWAC), as mentioned in section 5.4. Some researchers are also working on extraction of minerals and rare earth metals from the pumped seawater, such as lithium for electric batteries. Other by-products can include high-value cosmetics, production of sea-grapes, abalone, etc. In addition, by running small diameter

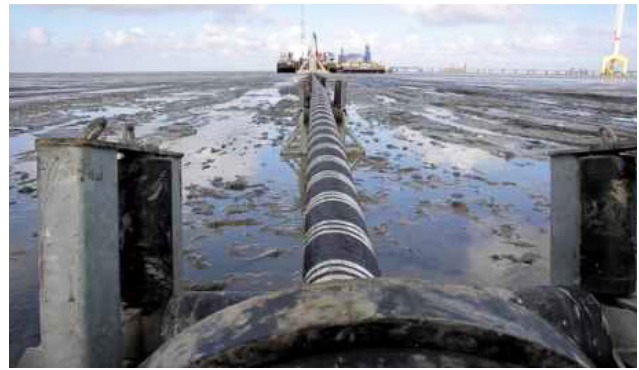

Figure 5.3 Export cable installation, Nordergunde offshore wind farm (Courtesy: Boskalis Subsea)



Figure 5.4 Example of a liquid ammonia transportation barge (tanker), four tanks

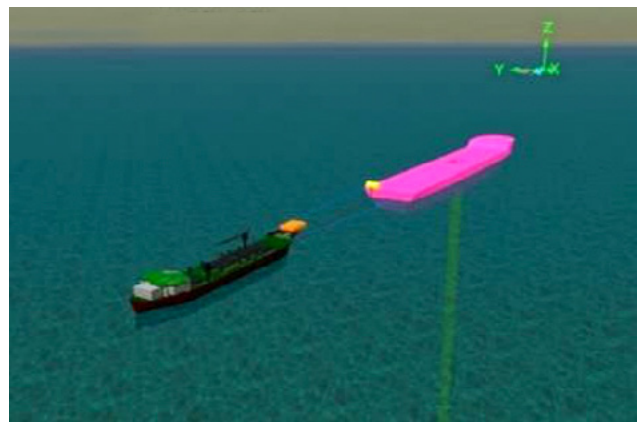

Figure 5.5 Example of floating OTEC system (Pink) with ammonia export via a hose to each 5,500 tons shuttle tanker (Courtesy: Strathclyde University)

pipes through the surface soil it is possible to irrigate via condensation from the air. This permits temperature-controlled agriculture that allows plants to grow quickly out of season. All these by-products, particularly when their use is included at the OTEC design stage, can improve the commercial attractiveness of a multi-product OTEC plant (Mac Takahashi, 2000). Both the Hawaii and Kumejima test sites are associated with significant additional product lines.

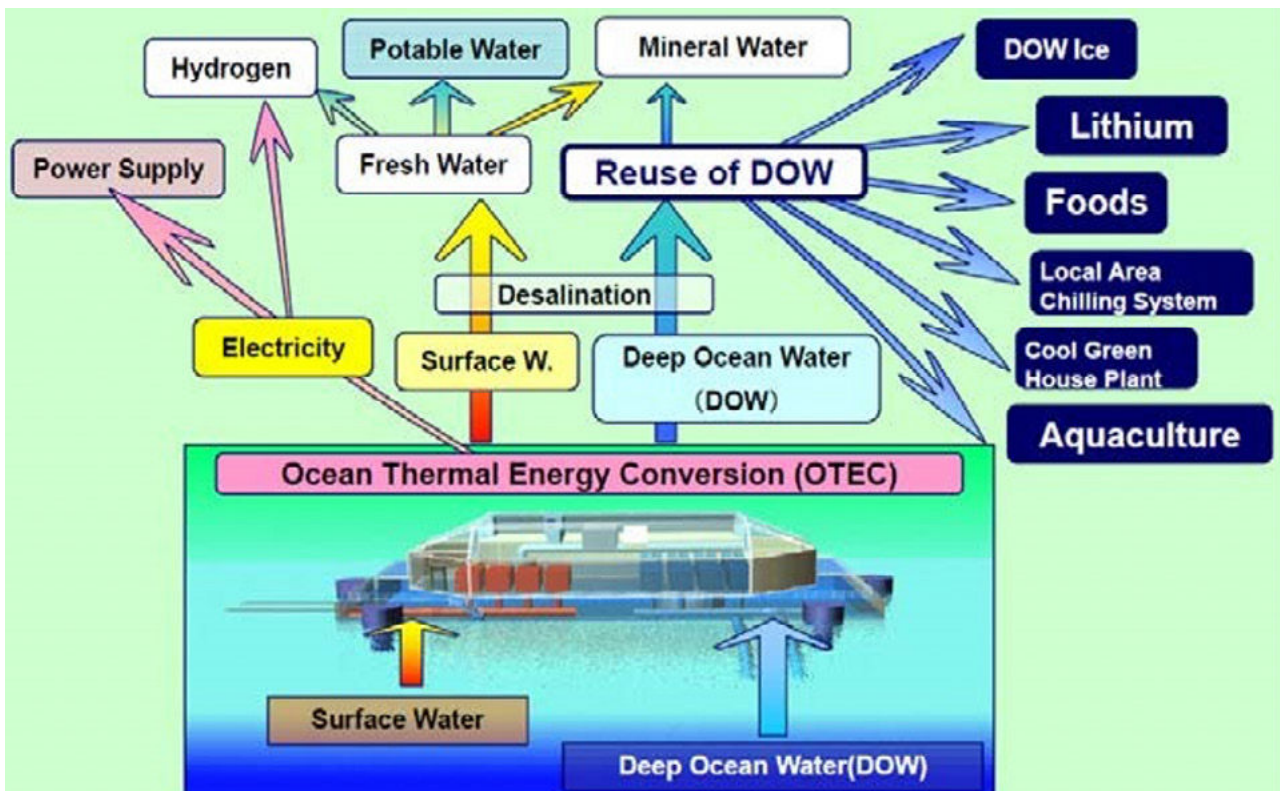

Figure 5.6 Illustration of a land based multi-product OTEC system (Courtesy: Prof. Ikegami)

## 5.4 Seawater Air Conditioning (SWAC)

In the tropics, conventional air conditioning is expensive due to large electrical power requirements, particularly for large complexes such as hotels, offices, hospitals, data centres, etc. However, depending on the proximity to deep cold ocean water SWAC can reduce normal electrical consumption by 80% to 90% (Figure 5.7). This substantial financial saving and the associated reduction in CO<sub>2</sub> emissions can help justify the installation of

the required seawater systems, as has been seen by a number of projects around the world. SWAC can either be undertaken as a standalone project or in conjunction with an OTEC development as might be the case for a new build eco-hotel on a tropical island – an example of which is the SWAC system at the International Intercontinental Hotel in Bora Bora, which has been operational since 2006.

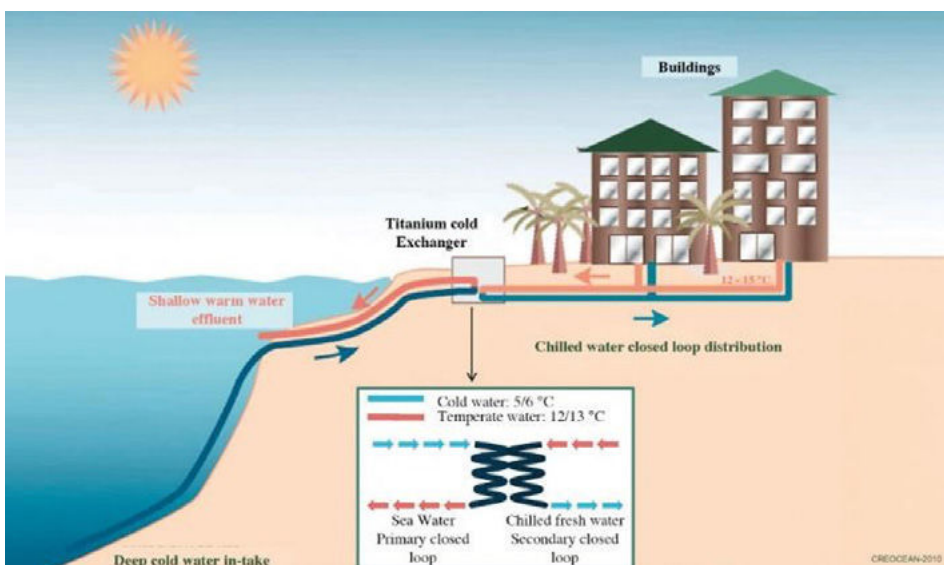

Figure 5.7 Illustration of Standalone Seawater Air Conditioning (SWAC). (Courtesy: Resinex/Crocean)

# 6.

## MAIN OTEC POWER GENERATION CYCLES

In general, there are three main types of OTEC power generation systems, namely:

- (a)** Closed cycle (CC) OTEC
- (b)** Open cycle (OC) OTEC
- (c)** Hybrid OTEC, basically a combination of a) and b).

These types can be explained as follows, all of which require a minimum warm to cold seawater temperature difference of approximately 20°C.

Closed cycle OTEC operates between pressures of 9.7 bar and 7 bar (1 bar = 1 atmospheric pressure), corresponding to the chosen working fluid (anhydrous ammonia in this case) at temperatures of 24°C and 14°C, respectively. In a closed cycle system liquid ammonia is pumped into an evaporator (heat exchanger) heated by warm seawater. The resulting ammonia vapour expands in a turbine producing mechanical power, which can drive a conventional electricity generator. The expanded vapour is then condensed back to a liquid using cold seawater in another heat exchanger. The liquid ammonia is then pumped back to the evaporator, thus allowing the cycle to continue.

Figure 6.2 shows a schematic of an open cycle OC-OTEC system. In OC-OTEC, a warm seawater stream is

partially vaporized inside a flash chamber kept under a high vacuum condition using a pump. This vapour, in a desalinated state, expands inside a large diameter low-pressure turbine and generates mechanical power, which drives a generator to produce electricity. The expanded vapour is then condensed using cold seawater. The condenser is kept at a lower pressure than the flash chamber due to the gas to liquid phase change. The pressure difference between the flash chamber and the condenser provides the driving force for the vapour to flow towards the condenser via the turbine. Typically, the water vapour temperatures at the inlet and outlet of an open-cycle OTEC turbine remain the same as the corresponding ammonia turbine in the closed cycle OTEC. If a surface rather than a spray condenser is used valuable freshwater can be produced as part of the electricity generation process.

A standalone seawater desalination system can be derived from an open cycle OTEC system by eliminating the turbine while keeping the remaining equipment configuration. This system is called low-temperature thermal desalination (LTTD) and has been very successful over several years at the Lakshadweep Islands in the Indian Ocean.

## Closed Cycle OTEC

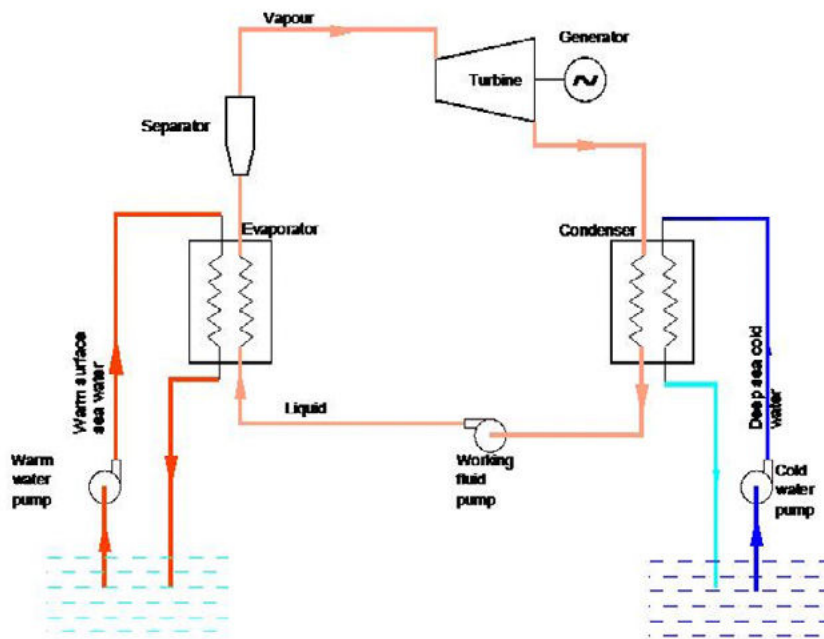

Figure 6.1 Schematic of closed-cycle OTEC

## Open Cycle OTEC with Sea Water Desalination

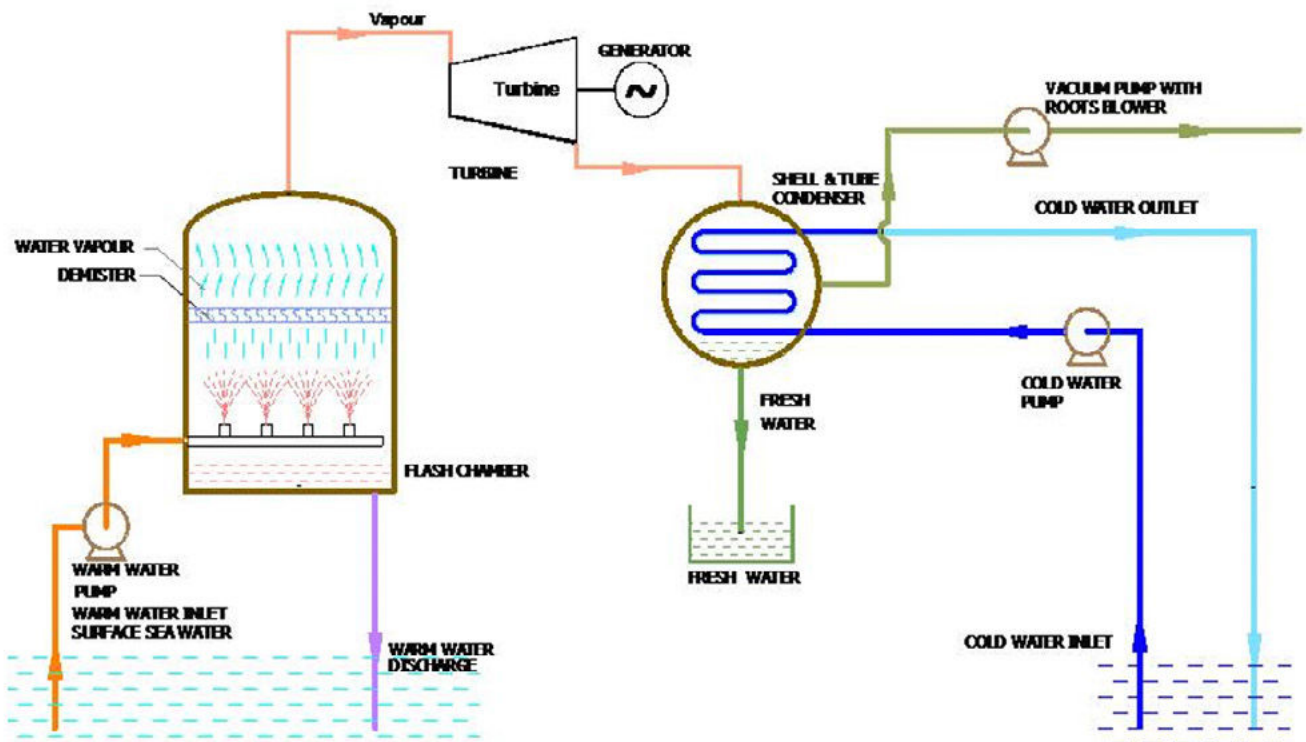

Figure 6.2 Schematic of open-cycle OTEC

# 7.

## ENVIRONMENTAL IMPACT OF OTEC

### 7.1 Environmental Impact - Emissions

OTEC is a benign electricity generation process with no noxious by-products. The following summarises the main benefits:

1. No fuel consumption
2. No emission of conventional air pollutants and particulates
3. No solid wastes
4. Post OTEC plant seawater is virtually identical to ambient water
5. Negligible emission of carbon dioxide.

If an open-cycle OTEC plant (see section 6) is selected, there is a small amount of CO<sub>2</sub> out gassed from the seawater as the pressure is reduced to allow flash evaporation. This is less than 1 percent of the approximately 700 grams per kWh released by a fuel oil power station (see Vega, in ref. 12). Based on present day technology large-scale floating OTEC plants are more likely to be closed rather than open cycle and for these plants CO<sub>2</sub> emissions are negligible.

### 7.2 Environmental Impact - Upwelling of Nutrient Rich Deep Clean Water

The OTEC process requires large quantities of nutrient-rich deep pathogen free ocean water to be pumped to the surface. This is an artificial form of the natural upwelling which occurs in parts of the oceans and results in greatly

enhanced biological productivity. This can be utilized for environmentally friendly marine aquaculture.

Within certain pre-defined parameters, it is possible to adjust the mix of warm and cold seawater released from an OTEC plant. The resulting temperature of the combined warm and cold water affects whether the nutrient rich water plume falls back to the depths below the photic zone or moves away in a more horizontal fashion. Conventionally, it has been considered desirable that once the warm and cold seawater has been through an OTEC plant the water should be released back to the ocean at an elevation and temperature such that the nutrients do not come to the surface. This is to minimise potential changes to marine ecosystems and for example, particularly for in-shore water or oligotrophic waters, avoid algal blooms, which can cause eutrophication (Giraud, 2019). More research works are needed for detailed study of this impact.

For deep sea locations and for non-moored grazing OTEC plants it may be desirable for nutrient rich clean water to be released such that it stays in the surface layers longer to help boost phytoplankton production through photosynthesis. Thus, the OTEC process could result in Carbon Dioxide Removal (CDR) in addition to producing electricity in an environmentally friendly manner. While the CDR potential of OTEC requires further research, it is noted that some early work on ocean artificial upwelling has been undertaken in Japan, see the Takumi Project illustrated in Figure 7.2.

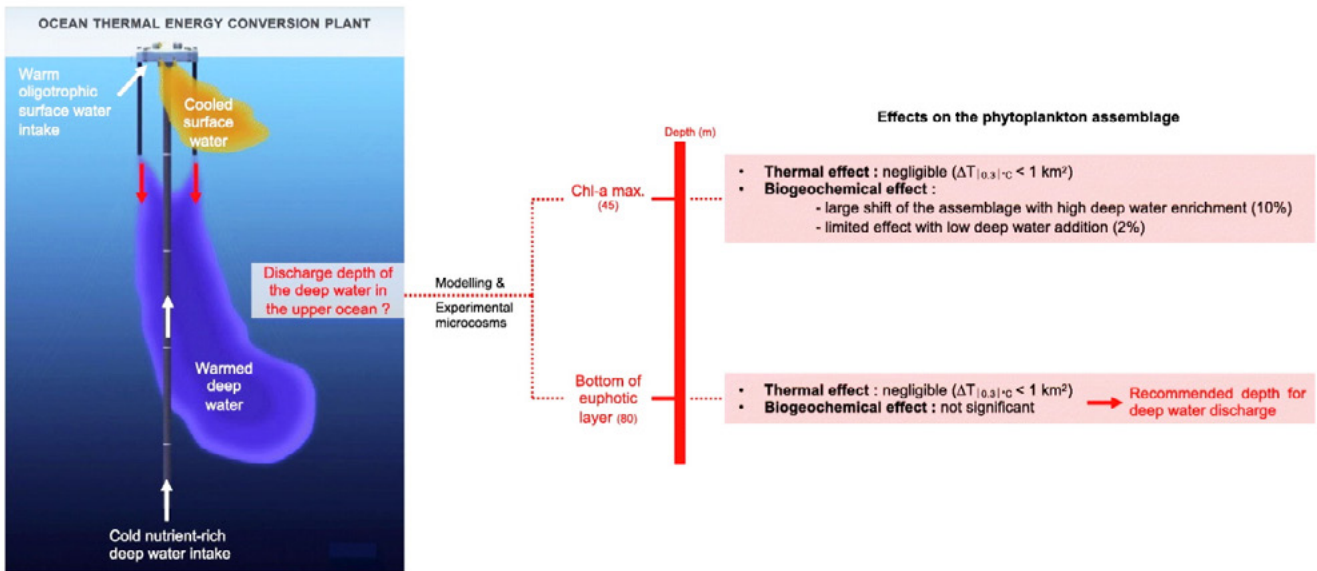

Figure 7.1 Discussion on the optimal depth for OTEC water discharge in oligotrophic waters (Giraud, 2019)

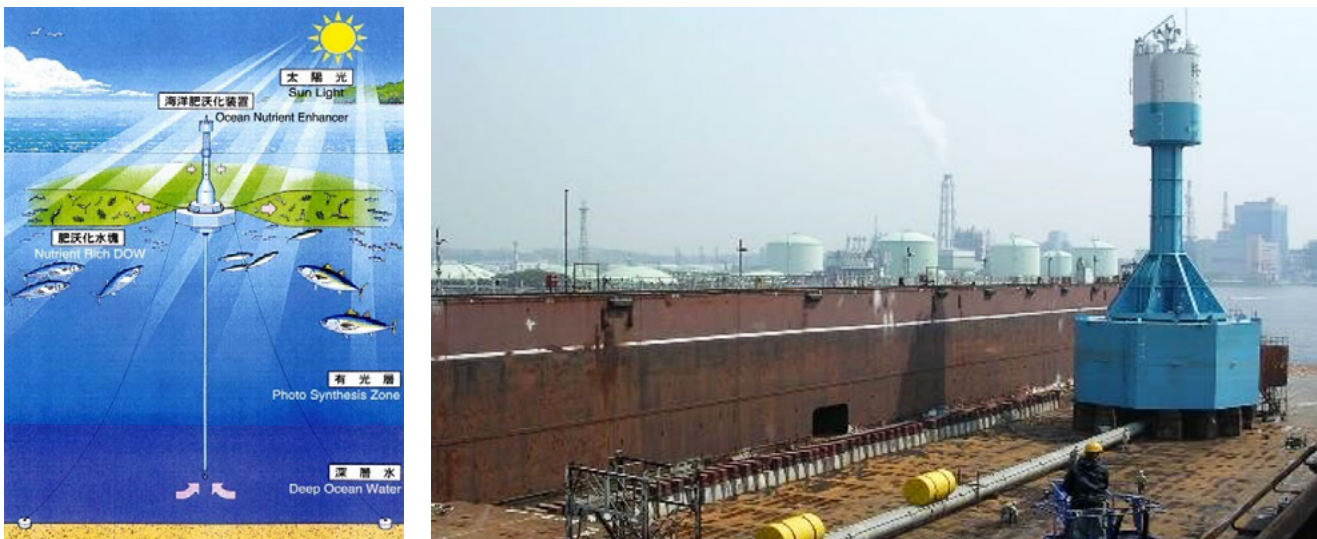

Figure 7.2 Illustration of Artificial Upwelling as demonstrated by the Takumi test project in Japan



### 7.3 Established History of Environmental Monitoring

The potential environmental impact of OTEC has been studied extensively over the last 40 plus years, particularly since the establishment of the Natural Energy Laboratory Hawaii in 1974 (Figure 7.3). Detailed environmental impact studies have been carried out and these are available in the public domain. Reassuring results have also been obtained at the Okinawa Deep Seawater Research Center (ODRC) on Kumejima island off Japan.

Figure 7.3 Aerial View of the Water Sampling Points at NELHA (Annual Report, June 2018)

# 8.

## TECHNOLOGY DEVELOPMENT STATUS

### 8.1 OTEC Power Cycle Equipment

Most components required for an OTEC system are either available off the shelf or do not require major redesigns to be optimised for OTEC. This includes pumps, heat exchangers, generators, control systems, cranes, hull, moorings, export power cable, fresh-water export hose/riser, etc. At larger scale there are still some uncertainties about heat exchanger performance over time and the best way to control biofouling. However, a significant quantity of field test data has been accumulated from work in Hawaii, Kumejima, Reunion Island, Saga University etc., which should be reviewed as part of any new OTEC design.

### 8.2 OTEC Engineering Standards

Over the last five years, two new engineering standards have been published by the International Electrotechnical Commission (IEC) and Bureau Veritas (Figure 8.1). These documents provide guidance and confidence to project developers that professional engineers can design systems that will behave as required and prove to be durable and reliable. In addition, many of the existing oil and gas standards are also applicable to floating OTEC systems. For example, the design of mooring systems for Floating Production Storage and Offloading units (FPSOs) or for the safe handling and storage of ammonia.

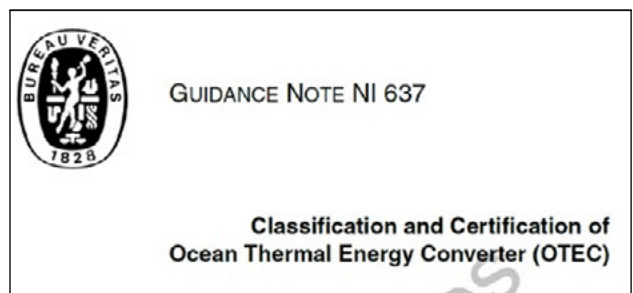

Figure 8.1 IEC and BV guidance for the design and certification of an OTEC Plant



### **8.3 Cold Water Pipe (CWP) Technical Status**

Continued structural integrity of the seawater supply and discharge pipelines under sustained long-term environmental and internal loadings is vital for a commercially successful OTEC plant. Various pipe materials such as High-Density Polyethylene (HDPE), Fibre Reinforced Plastics (FRP), flexible canvas (fabric materials) have been investigated with respect to structural strength and ease of installation. Despite this work, some challenges remain in the installation of very large diameter pipes and their integrity throughout the design life of the OTEC system. These challenges may well be overcome thanks to recent advancements in offshore handling installation capacities, extensive R&D on pipe materials (Figure 8.2) and new design approaches, which together should provide improved durability and economy.

The next two sections review the present technical limit for pipeline diameters for both land based and floating OTEC systems.

### **8.4 Circa 2.5 MW Land Based OTEC Technically Achievable Today**

A circa 2.5 MW land based OTEC plant will require a CWP diameter of approximately 2.5 m. This is an HDPE size which is available from suppliers and was installed for the seawater intake pipe for the Ras Djinet Gas Turbine Combined Cycle power plant in Algeria, see Figure 8.3 (Kim, 2015). A 2.5 m diameter CWP is also similar to the 1/3 scale “down the slope” pipeline test carried out in Hawaii, as is illustrated in Figure 8.4 and Figure 8.5. In practice, a CWP diameter limit for a land-based plant is set by keeping the installation cost to a reasonable figure using existing proven techniques and locally available tugs, lower cost crane vessels, etc. Larger pipes can be installed but will require the enhancement of existing techniques and potentially mobilising expensive vessels out with the local area.

A 2.5 MW power output represents a useful baseload power supply for many Small Island Developing States (SIDS). From a return-on-investment (ROE) point of view, it can be difficult to justify the relatively high CAPEX associated with the installation of the seawater systems for a relatively small-scale 2.5 MW system. ROE can be helped by additional revenue streams from an eco-resort multi-product OTEC development. Apart from the seawater intake systems, the rest of the equipment for a 2.5 MW system is conventional and should be reliable, as has been demonstrated in Hawaii and also Kumejima. Recent

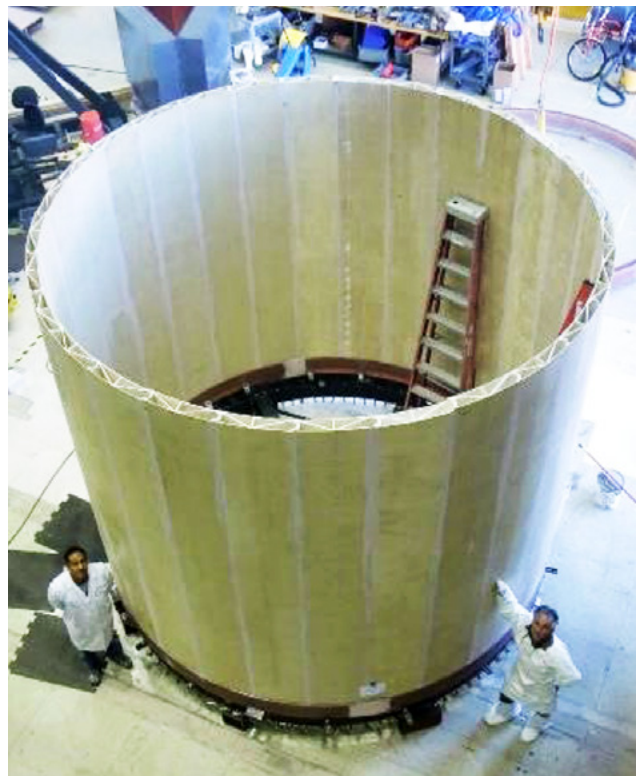

**Figure 8.2** Lockheed Martin’s CWP R&D programme with a 4 m pipe next to two engineers



**Figure 8.3** Concrete collars on a 2.5m water intake pipeline, Ras Djinet Gas Turbine Power Plant, Algeria

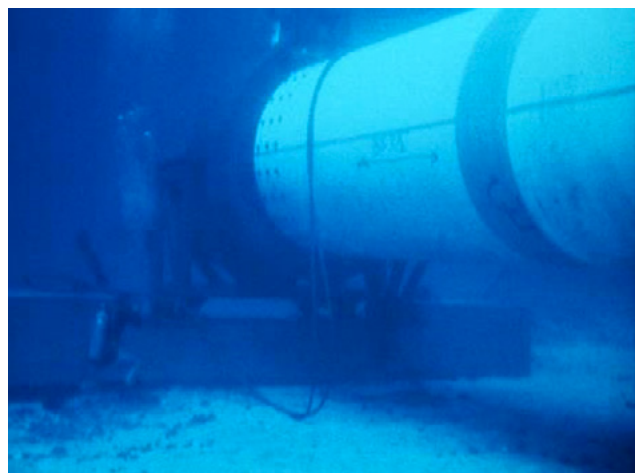

**Figure 8.4** 8 foot (2.44m) down the slope test programme in Hawaii (Courtesy: Dr. Luis Vega)

contact with the industry suggests that the provision of a feed-in tariff for OTEC generated electricity is important to increase the appeal of this type of project to commercial investors.

### **8.5 10 MW Floating OTEC Technically Achievable Today**

A 10 MW floating OTEC power plant requires a CWP diameter of approximately 4m (Lockheed Martin, 2010). This size is judged to be technically achievable today, particularly for areas of the world not subject to tropical revolving storms, which includes a significant area band around the equator. This CWP size limit takes into account oil and gas FLNG experience (e.g., Shell's Prelude seawater intake system, OTEC-1 CWP deployment plus Lockheed Martin's substantial R&D work).

The remaining balance of plant components for a floating OTEC system, like for the land-based system, is conventional in nature. Hence, a 10 MW floating OTEC system is judged to be technically feasible using present day technology, although the capital cost is relatively high – see section 9.2.

### **8.6 Floating OTEC Utilising Oil and Gas Floating Production Technology and Redundant Vessels**

The oil and gas industry has made great progress over the last twenty-five years particularly with regards to floating productions systems (FPSOs and FLNGs). Today, mooring a FPSO/FLNG in 1,500 m of water is no longer considered noteworthy. A more recent development has been making use of sub-surface water for process equipment cooling of production units in the tropical oceans. A particularly interesting example is Shell's vast Prelude FLNG system, which is shown in Figure 8.6, where a bundle of deep-water intake risers can be seen at the stern. The successful installation of the Prelude risers shows that the oil and gas industry have the knowledge and experience to solve challenges, such as the OTEC seawater intake and discharge pipelines.



**Figure 8.5** Illustration of the 2.44 m pipeline on a 30-degree slope test diver



**Figure 8.6** Shell's Prelude FLNG system with deep water intake risers shown at the Stern

# 9.

## ROAD-BLOCKS TO DEVELOPMENT

### 9.1 Absence of a 2.5+ MW Demonstration Unit

Two 1-MW sized floating OTEC plants have operated to date, namely the South Korean K-OTEC1000 Barge illustrated on the front cover and the OTEC-1 test facility off Hawaii. OTEC-1 was planned to operate for three years, but after a change in American administration only operated for four months. The K-OTEC1000's deployment was also shorter than planned due to safety concerns related to a late summer typhoon. From the outset K-OTEC1000 was designed as a temporary test facility for the heat exchangers and turbine. This floating test was to check the performance of the process equipment prior to its transportation to Kiribati in the Central Pacific Ocean for a land-based project, which is still planned to be undertaken, but has been delayed.

For the private sector to invest in a new renewable energy system, investors typically want to see proven performance data at a reasonable scale over an extended period, since this reduces project risk. Operational data also makes it easier to scale up to a larger project. Therefore, there is an **urgent need for a larger scale (2.5 MW or more) demonstration project to run for approximately two plus years to provide reliable operational data.** The 2.5 MW limit is based on ensuring the pipeline deployment

“

**There is an urgent need for a larger scale (2.5 MW or more) demonstration project to run for approximately two plus years to provide reliable operational data.**

costs are contained – see section 8.4. It is likely that such a project will be land-based since this saves the expense of people living offshore, moorings power export cable, etc. A land-based system can also more easily benefit from OTEC byproducts such as production of freshwater, aquaculture, reduced costs air conditioning, etc. However, if there is a market demand for a floating system at a specific island location, the operational data would be equally beneficial.

## 9.2 High CAPEX/LCOE Estimates for Prototypes up to 100 MW Size

To date, a key obstacle to the large-scale adoption of OTEC has been the relatively high estimated CAPEX associated with such projects. Table 9.1 compares the Levelized Cost of Energy (LCOE) for 10 and 100 MW OTEC systems with solar, wind, gas, nuclear and coal. This figure illustrates how the selected interest rate influences the LCOE. One conclusion from this table is that the LCOE from OTEC seems higher compared to solar or wind, although it depends on whether you select the minimum or maximum estimate. For the 100 MW size plant (adjusted interest rate) it is apparent that there is a factor of 7.25 between the lowest and the highest estimates, which indicates a significant degree of uncertainty. While the paper from which the table is obtained is dated from 2020, the source data is significantly older, going in general back to 2011 to 2012. Clearly, cost estimates can change significantly over a period of 9 to 10 years.

Also, it should be noted that the maximum size of OTEC system in this table is limited to 100 MW. 400 MW designs for floating OTEC systems have been developed and such large-scale units will have a lower LCOE and benefit from cost reductions due to standardisation and mass production techniques. As the energy transition picks up pace it will become apparent that certain renewable technologies are particularly suitable for certain markets. Electricity, fresh water and reduced cost air conditioning are particularly valuable in tropical locations, where the best OTEC thermal gradients can be found.

In general, the scale of the OTEC resource is so vast and the synergy between OTEC and the oil industry is so high **it is important that more up to date cost estimates are undertaken by suitably experienced personnel** – see section 10.1.

Energy Technology (Unsubsidised)	LCOE [US\$(2018)/kWh]
10 MWe OTEC (original interest rate)	0.15
10 MWe OTEC (adjusted interest rate)	0.20 – 0.67
100 MWe OTEC (original interest rate)	0.03 – 0.22
100 MWe OTEC (adjusted interest rate)	0.04 – 0.29
Solar PV Crystalline Utility Scale	0.04 – 0.046
Wind	0.029 – 0.056
Gas Peaking	0.152 – 0.206
Nuclear	0.112 – 0.189
Coal	0.06 – 0.143
Gas Combined Cycle	0.041 – 0.074

**Table 9.1** Estimated LCOE for OTEC plants vs other renewable and conventional energy sources (Langer, J., 2020)

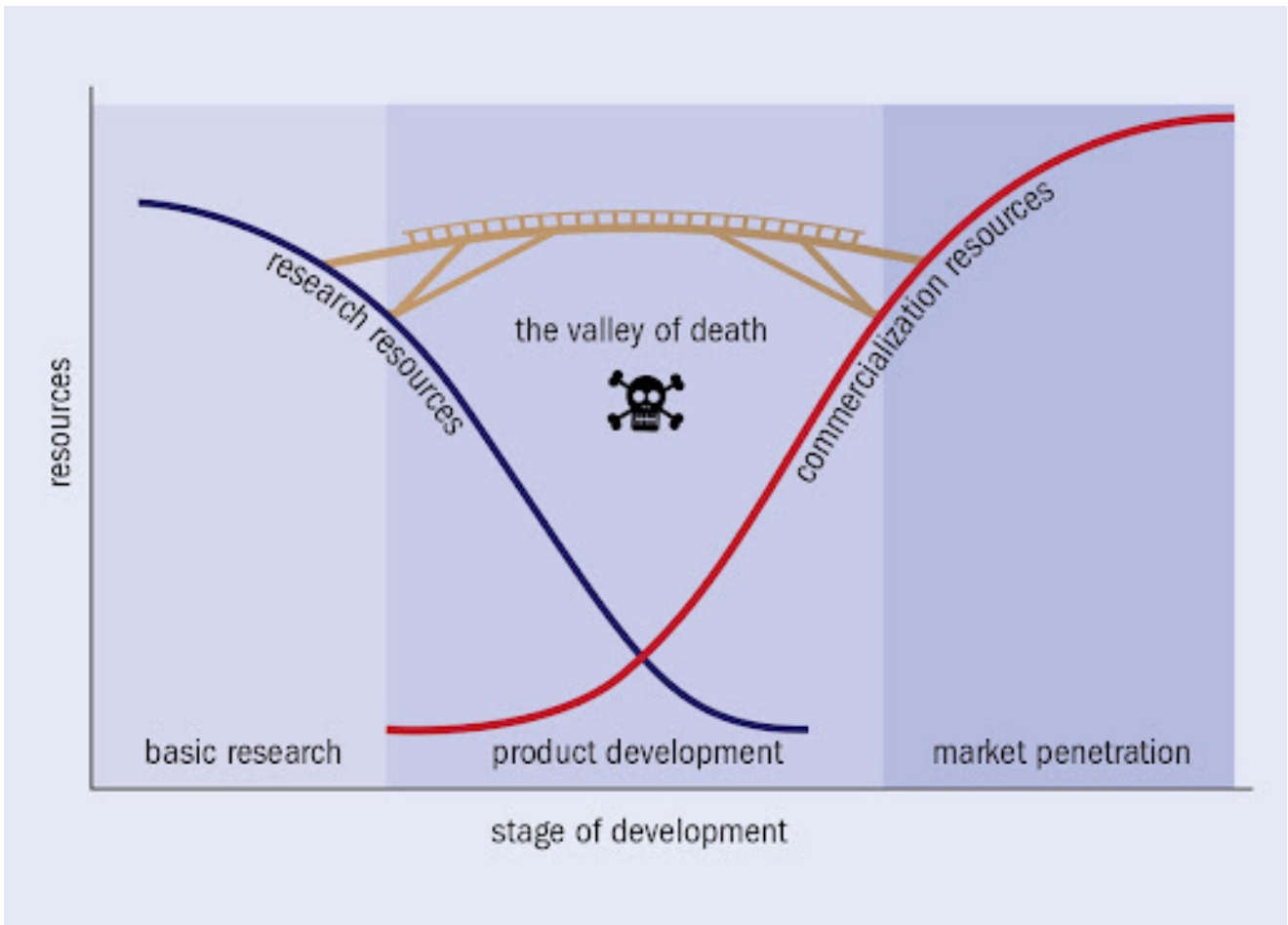

Figure 9.1 Illustration of the "Innovation Valley of Death"

### 9.3 Lack of Incentives to Overcome the Innovation Valley of Death

OTEC progress is presently constrained by the Innovation Valley of Death as is illustrated in Figure 9.1. Basically, there is a "Catch 22" situation in that smaller pre-commercial OTEC plants are not commercially attractive but results from such facilities are needed to convince financiers that the risk is manageable considering the size of the potential market. Hence, the need for additional government support to build and operate a pre-commercial plant for a few years.

### 9.4 Lack of OTEC Knowledge within Governments and the General Public

Since OTEC is not well known it is rarely discussed and there is a lack of understanding as to how much work has been done in the past and the full potential of the technology. For example, OTEC is sometimes completely omitted in events where the potential of ocean renewable energy is discussed. A new, international, not-for-profit Ocean Thermal Energy Association (OTEA), has been formed to promote and explain the potential of OTEC (see <http://www.ocean-thermal.org/>).

# 10.

## RECOMMENDATIONS FOR POLICYMAKERS

### Commission Up to Date Cost Estimates

As is discussed in section 9.2 there is a high degree of uncertainty associated with the reported cost estimates for OTEC, which primarily are 10 years old or older. Therefore, it is important to commission **new studies to update cost estimates based on present day costs and technology**. In addition, design concepts from over 10 years ago should be reviewed/updated that consider modern oil and gas floating production, drilling and energy storage technologies. It may also be that there is now potential to combine OTEC with offshore wind so that the cost of the associated energy export infrastructure can be shared across two or more income streams.

### Introduce Financial Incentives to Invest and Provide R&D Support

In the current climate there is a reluctance for any commercial organization to self-finance all the development costs of an OTEC system. This is partly due to the innovation valley of death as discussed in section 9.3 and a lack of a market guaranteed by incentives such as feed-in-tariffs or other financial risk supportive policies. Hence, it is vital to **introduce OTEC feed-in-tariffs as well as grants for research, development and demonstration** to encourage private enterprises to invest.

### Encourage Establishment of a Pre-Commercial Demonstration Site (Multi-Products and Sea Water Air Conditioning)

Section 9.1 discusses the importance of there being an operational pre-commercial demonstration unit of 2.5 MW or more. Policymakers and planners are ideally placed to encourage the development of such facilities. A potential example of such a complex is the proposed Puerto Rico Ocean Technology Complex (PROTech), which has been proposed and encouraged by the Puerto Rico government (Figure 10.1 and Figure 10.2). It would be highly desirable to see regional multi-product OTEC centres (for example in the Caribbean, Pacific, Indian Ocean, Celebes Sea), where internationally funded research could be carried out.

One or more successful pre-commercial OTEC demonstration centres will provide confidence about the potential of OTEC technology to: Banks/venture capitalists, classification and certification bodies, public authorities, governments, consultants, design engineers, general public.

### Encourage Countries to include OTEC in National Energy and Climate Plans

It is sensible and potentially beneficial for all countries to properly understand the full range of resources which they can access. Hence, OTEC should be included whenever renewable energy resources are being assessed for both energy and climate plans. Each nation should individually assess and document their national OTEC/DOWA resource including any overseas dependencies.

**Figure 10.1**  
Proposed Multi-Product Puerto Rico Ocean Technology Complex (PROTech)



### Encourage Technology Transfer from Offshore (FLNG/FPSOs)

The skills and experience of the offshore oil industry are vital for successful OTEC projects and cooperation is needed between developers and this industry. There may also be an option to reduce CAPEX by re-using redundant oil industry assets such as drill ships, FPSOs etc. which still have many years of useful life and at present are being prematurely scrapped. This co-operation can be encouraged by research and development grants and by Joint Industry Project (JIP) initiatives to share development costs and maximize sharing of information. This type of partnership may also provide the offshore industry a transformative pathway into the renewable energy sector, while **supporting the UN's Sustainable Development Goals.**

### Ensure a Clear Legal Framework for accessing the OTEC Resource

It is logical that prior to installing any floating OTEC systems in international waters the legal framework for operations should be clear. Work on this has been done in the past, but it should be revisited. Most legal agreements take time to finalize and thus it is important that this process starts in good time, so that it does not cause unnecessary delays.



**Figure 10.2** Close up of the PROTech Central Complex

# 11.

## CONCLUSIONS

**At present, the biggest barrier to more widespread adoption of OTEC technology is financial and not technical, particularly at a scale below 10 MW. The basic electricity generation process system is simple and has proven to be reliable at both the Hawaii Natural Energy Laboratory and at the Okinawa Deep Seawater Research Center. What is missing is the financial guarantee to move beyond small demonstration plants to pre-commercial prototype units, which will provide key operational performance data needed to encourage investment in even larger commercial-scale facilities.**

Financial incentives, such as feed-in tariffs are required to encourage these developments. In addition, more research is needed to scale up to an OTEC plant larger than 10 MW. In particular, this should address the required large size of the Cold Water Pipe and how assurance can be gained that these vital components of the system will prove reliable over decades of use. Oil industry experience should be sought including numerical simulations, design optimization, wave tank model testing, etc.

Presently, there is a lack of knowledge about OTEC both within governments and the public. Hence, more education and publicity are needed to explain the green benefits of the technology. Support to establish such an education programme would logically fall to intergovernmental agencies.

It is also vital to encourage international co-operation between national governments to share information, plan joint projects, pool funding and potentially eliminate duplicated work. At the same time, the skills and experience of the private sector should be sought including project developers, venture capitalists, banks, consultants, contractors, oil and utility companies, classification companies, etc. Again, inter-governmental agencies have an important role to facilitate communication between national governments and the private sector.



## Future Road Map

The most accessible market in the short and medium-term has been assessed to be as follows:

**1.**

Land-based 2.5 MW plus demonstration units (electricity production and spin-offs: desalinized water, seawater air conditioning, etc.) particularly for small island developing states (SIDS) in the tropical oceans.



**2.**

Offshore - moored 10 MW (net) with power cable export to a suitable grid connection.



**3.**

Offshore - grazing mode 100 MW + with on-board generation of ammonia or methanol as the energy (hydrogen) export carrier via dedicated shuttle tankers.

# 12.

## REFERENCES

1. Adiputra R., *et al.*, “Preliminary design of a 100 MW-net ocean thermal energy conversion (OTEC) power plant study case: Mentawai Island, Indonesia”, *Journal of Marine Science and Technology* (2020) 25:48–68.
2. Giraud M. *et al.*, “Potential effects of deep seawater discharge by an Ocean Thermal Energy Conversion plant on the marine microorganisms in oligotrophic waters”, *Science of the Total Environment*, vol. 693, Nov. 2019, Elsevier;  
<https://doi.org/10.1016/j.scitotenv.2019.07.297>
3. Kim, 2015, HDPE Sea Water Intake for Ras Djinet Combined Cycle Power Plant Project, Pipeline Technology Conference.
4. Langer J., *et al.*, “Recent progress in the economics of ocean thermal energy conversion: Critical review and research agenda” *Renewable and Sustainable Energy Reviews*, 130, 2020.
5. Lockheed Martin, NAVFAC OTEC Technology Development Report Contract N62583-09-C-0083, CDRL A002, 2010.
6. Nihous G.C., 2, 043104, JRSE, 2010; from NODC WOA05 database.
7. Nihous G.C., A Preliminary Investigation of the Effect of Ocean Thermal Energy Conversion (OTEC) Effluent Discharge Options on Global OTEC Resources, *J. Mar. Sci. Eng.* 2018, 6, 25;  
<https://www.mdpi.com/2077-1312/6/1/25>
8. Talley L. D., *Hydrographic Atlas of the World Ocean Circulation Experiment (WOCE). Volume 2: Pacific Ocean* (eds. M. Sparrow, P. Chapman and J. Gould), International WOCE Project Office, Southampton, UK, ISBN 0-904175-54-5. 2007.
9. Masayuki Mac Takahashi “DOW Deep Ocean Water as Our Next Natural Resource”, 2000, Terra Scientific Publishing Company, Tokyo, Japan.
10. Martinez M.L. *et al.* (2021): A systemic view of potential environmental impacts of ocean energy production. *Renewable and Sustainable Energy Reviews*.  
<https://doi.org/10.1016/j.rser.2021.111332>
11. Rauchenstein L.T., (2012) “Global Distribution of Ocean Thermal Energy Conversion (OTEC) Resources and Applicability in U.S. Waters near Florida” M.S. Thesis, Florida Atlantic University.
12. Chapter 3.4. Ocean Thermal Energy, Luis Vega (2014) in “Offshore Renewable Energy Current Status – Future Perspectives for Portugal” ISBN 978-972-8826-30-7, OTEO.





[www.ocean-energy-systems.org/](http://www.ocean-energy-systems.org/)